



## The Corporation of The Township of Bonfield

### AGENDA FOR COUNCIL MEETING TO BE HELD February 27th, 2024 AT 7:00 P.M.

1. **Call to Order**
2. **Adoption of Agenda**
3. **Disclosure of Pecuniary Interest and General Nature Thereof**
4. **Adoption of previous minutes**
  - a. Regular Meeting of Council: February 13, 2024
  - b. Notes from Council Finance Retreat of February 15, 2024
5. **Presentations and Delegations**
  - a. Kevin Rose – Policy Change on Minimum Size of Permanent Dwelling
6. **Staff Reports**
  - a. Report from Recreation Committee Secretary – Canada Day Entertainment
  - b. Report from Planning Administrator - Sale and disposition of land re Beath, Patrina and Jeffery
  - c. Report from Planning Administrator - Forming a not-for-profit committee – History of Bonfield
  - d. Report from Public Works Manager – Unmaintained Roads Policy
  - e. Report from CAO/Clerk - User Fees Review
7. **Adoption of Committee Minutes/ Motions**
  - a. **Corporate Services Committee:** Next meeting March 5, 2024
  - b. **Emergency Services Committee:** February 12, 2024
  - c. **Planning Advisory Committee:** No Minutes for this session
  - d. **Recreation Committee:** No Minutes for this session
  - e. **Police Services Board:** No Minutes for this session
8. **Items for Council Discussion** (none for this session)
9. **Resolutions to be Considered for Adoption**
  - a. By-law 2024-10 being a by-law to enter into an agreement with NBHS for the provision of animal control services
  - b. By-law 2024-12 being a by-law for the closure and sale of shore road allowance re Thompson
  - c. By-law 2024-13 being a by-law for the closure and sale of shore road allowance re Fleckney
  - d. Municipality of Calvin – provincial & national fire fighting strategy
  - e. City of Brantford - reliable and accessible public rail transit - CN Rail letter
  - f. Letter from DNSSAB Chair Mark King regarding Reaching Home Funding.
  - g. Bonfield Lions Club's request for use of parking lot and picnic tables for annual ATV run

*Small Community, Big Heart*



10. **Correspondence**
  - a. 2024 DNSSAB Levy
  - b. DNSSAB Press Release re New CAO
  - c. Ministry of Transportation – Changes to Licence Plate Renewal
  - d. 2024 Cassellholme Levy
  - e. Federation of Canadian Municipalities – 2024 Annual Conference
  
11. **Closed Session**
  
12. **Confirmatory By-Law**
  - a. Resolution to adopt By-law No. 2024-09
  
13. **Adjournment**



THE CORPORATION OF THE TOWNSHIP OF BONFIELD  
REGULAR MEETING OF COUNCIL  
February 13<sup>th</sup>, 2024

PRESENT: Narry Paquette Jason Corbett  
Donna Clark Steve Featherstone  
Dan MacInnis

STAFF PRESENT: Andrée Gagné, Deputy Clerk  
Alex Hackenbrook, Public Works Manager  
Nicky Kunkel, CAO/ Clerk Treasurer

**No. 1 Call to Order**

**No.1**

Moved by Councillor Corbett  
THAT this meeting be opened at 7:00 p.m.

Seconded by Councillor Clark

Carried Narry Paquette

**No. 2 Adoption of Agenda**

**No.2**

Moved by Councillor Featherstone  
THAT the agenda presented to Council and dated the 13th day of February 2024, be adopted as prepared.

Seconded by Councillor MacInnis

Carried Narry Paquette

**No. 3 Disclosure of Pecuniary Interest:** None for this session

**No. 4 Adoption of Previous Minutes**

**No.3**

Moved by Councillor Clark  
THAT the Minutes of the Regular Council Meeting of January 30th, 2024 be adopted as circulated.

Seconded by Councillor Corbett

Carried Narry Paquette

**No. 5 Presentation & Delegations** (none for this session)

**6. Staff Reports**

6.a Report from Deputy Clerk regarding renewing the Animal Control contract with the North Bay & District Humane Society

**No.4**

Moved by Councillor Featherstone  
THAT the contract with the North Bay & District Humane Society be renewed for a one-year term; AND THAT staff provide a full cost analysis report on providing the services in-house versus contracting out to the North Bay & District Humane Society.

Seconded by Councillor MacInnis

Carried Narry Paquette

**7. Adoption of Committee Minutes/ Motions** (none for this session)

**8. Items for Council Discussion**

8.a 2024 FONOM Conference – May 6 – 8, Sudbury

**No.5**

Moved by Councillor Featherstone  
WHEREAS the 2024 FONOM Conference is being held at the Holiday Inn in Sudbury May 6 – May 8th, 2024; BE IT HEREBY RESOLVED that Narry Paquette be approved to attend the 2024 FONOM Conference; AND THAT all expenses be paid in accordance with the Township policies.

Seconded by Councillor MacInnis

Carried Narry Paquette

## 9. Resolutions to be Considered for Adoption

9.a By-law 2024-08 being a by-law to amend By-law 2023-48 being a by-law to govern the proceedings of Council.

### No.6

Moved by Councillor Clark

Seconded by Councillor Featherstone

That By-Law 2024-08 being a by-law to amend By-Law 2023-48 To Govern the Proceedings of The Council regarding committees, hereby be considered read three times and passed this 13th day of February 2024.

Carried Narry Paquette

9.b Appointing of a member to sit on the Hiring Committee for the CBO/By-Law Enforcement position

### No.7

Moved by Councillor Corbett

Seconded by Councillor MacInnis

THAT Councillor Corbett and Councillor MacInnis be appointed to sit on the hiring committee for the CBO/ By-Law Enforcement position.

Carried Narry Paquette

9.c Appointing of a member to sit on the Hiring Committee for the Fire Chief position

### No.8

Moved by Councillor Featherstone

Seconded by Councillor Clark

THAT Councillor Featherstone and Councillor Clark be appointed to sit on the hiring committee for the Fire Chief position.

Carried Narry Paquette

9.d MP Todd Doherty requiring the posting of 988 posters in all municipal buildings

### No.9

Moved by Councillor Featherstone

Seconded by Councillor Corbett

WHEREAS Canada has adopted 988, a National three-digit suicide and crisis hotline; AND WHEREAS the Township of Bonfield recognizes that it is a significant and important initiative to ensure critical barriers are removed to those in a crisis and seeking help; NOW THEREFORE BE IT RESOLVED THAT the Township of Bonfield continues to endorse the 988-crisis line initiative; and will display the 988-information poster in all Municipal/City buildings.

Carried Narry Paquette

9.e Town of Mono declares road safety emergency

### No.10

Moved by Councillor MacInnis

Seconded by Councillor Featherstone

THAT the Council for the Township of Bonfield supports the Town of Mono calling on the Province to take action to address traffic safety tough measures including public education, increased Highway Traffic Act fines and expanded use of Automated Speed enforcement

Carried Narry Paquette

9.f Prince Edward County regarding expanding the life cycle of fire apparatus

### No.11

Moved by Councillor Corbett

Seconded by Councillor Featherstone

THAT the Council of the Township of Bonfield supports the Prince Edward County's motion requesting the Province to expand the life span of fire apparatus, specifically pertaining to the replacement of fire trucks due to insurance requirements.

Carried Narry Paquette

9.g City of Mississauga seeking reforms to the Landlord and Tenants Board

### No.12

Moved by Councillor Clark

Seconded by Councillor Featherstone

That the Council for the Township of Bonfield supports the City of Mississauga calling on the Province to implement significant reforms at the Landlord and Tenant Board to alleviate the housing and homelessness crisis.

Carried Narry Paquette

9.h Clearview Township seeking cemetery transfer/ abandonment Administration & Management support.

**No.13**

Moved by Councillor Featherstone

Seconded by Councillor MacInnis

THAT the Council for the Township of Bonfield supports the recommendations outlined in the letter from Clearview Township pertaining to the operation of a cemetery.

Carried Narry Paquette

9.i Township of Georgian Bluffs asking the Province to undertake a comprehensive social and economic prosperity review

**No.14**

Moved by Councillor Featherstone

Seconded by Councillor Clark

THAT the Council for the Township of Bonfield supports the Township of Georgian Bluffs calling on the Province to undertake, along with the Association of Municipalities of Ontario, a comprehensive social and economic prosperity review to promote the stability and sustainability of municipal finances across Ontario.

Carried Narry Paquette

**10. Correspondence**

**No.15**

Moved by Councillor Featherstone

Seconded by Councillor Corbett

THAT Council receives the Correspondence circulated with the Agenda of February 13, 2024.

Carried Narry Paquette

**11. Closed Session (none for this session)**

**12. Confirmatory By-Law**

**No.16**

Moved by Councillor Featherstone

Seconded by Councillor MacInnis

THAT the Council for the Township of Bonfield hereby adopts By-Law 2024-07 to confirm the proceedings of Council from January 30th, 2024 to February 13th, 2024, as presented and considered read three times and passed this 13th day of February 2024.

Carried Narry Paquette

**13. Adjournment**

**No.17**

Moved by Councillor Featherstone

Seconded by Councillor MacInnis

THAT this meeting be adjourned at 7:28 p.m.

Carried Narry Paquette

---

MAYOR

---

CLERK



THE CORPORATION OF THE TOWNSHIP OF BONFIELD  
Finance Retreat Notes  
February 15, 2024, at 7:00 p.m.

PRESENT: Narry Paquette Jason Corbett Donna Clark  
Dan MacInnis Steve Featherstone

STAFF PRESENT: Nicky Kunkel, CAO Clerk-Treasurer  
Alex Hackenbrook, Public Works Manager

The retreat started at 7:00 pm in the Committee room at the Municipal Office.

1. Financial Indicators

The CAO reviewed the Ministry of Municipal Affairs Financial Indicators for the Township of Bonfield with Council. These are annual financial ratios and comparators conducted by the province for all municipalities. The only indicators that were above the “low” risk are taxes receivable, debt servicing and closing amortization as a percentage of capital assets. Overall, there is caution that the Township is not reinvesting in capital or reserves to meet future capital demands but there is a stable cash flow and savings to withstand a municipal emergency.

2. Reserves / Predictable Funding

The CAO presented a summary of the current reserve accounts and their balances. Council also received confidential information on the investments of the Township and a summary of the predictable funds from the province. In summary the reserves are booked at \$1,749,293. The total investments are recorded at \$1,292,596. Taking into account the bank account, deferred revenues (net 2023) and taxes receivable there remains an unfunded amount of \$319,590.

3. Infrastructure Needs

Council was presented with a summary of core infrastructure needs as it currently sits with the 2023 Road Needs Study and the 2022 Bridge and Culvert Inspection Study. The Roads Needs Study was just received in the past two days, so Council has not yet received this report as it remains in draft form. Using the numbers within these documents it was explained that there is currently an asset deficient of \$3, 837,746 in 2024 with an expected additional spending estimate of \$4,959,765. This is for current core infrastructure only.

Council was also presented with a summary of the current debt servicing. The Township has an ARL of \$639,620 as set by the province. Comfort levels for debt servicing are around 50% of the ARL which would be \$319,810. In 2023 the annual repayment was \$194,198 and in 2024 it will be \$209,646 leaving \$101,164 in comfortable debt servicing for future infrastructure needs. This represents outstanding loans of \$2,225,750 for principal only.

4. 2024 Workplan

Discussion occurred about balancing the infrastructure needs with affordability and sustainability. While the intent of the meeting was to determine the financial state of the Township for setting the Strategic Plan and Council’s goals and objectives for the remainder of the term, Council instructed the information be shared in a summary format at the March 7, 2024, Townhall Meeting. The discussion will continue with community input and during budget deliberations.

The retreat adjourned at 10:10 pm.

## Andrée Gagné

---

**From:** kevin rose <krosey24@hotmail.com>  
**Sent:** February 13, 2024 3:07 PM  
**To:** Nicky Kunkel  
**Subject:** Meeting

You don't often get email from krosey24@hotmail.com. [Learn why this is important](#)

I request 5 minutes of councils time on the 27th of February 2024 to discuss policy changes based on the minimum size of perment dwelling thank you for your time

---

## REPORT TO COUNCIL

---

**MEETING DATE:** February 27<sup>th</sup>, 2024  
**FROM:** Casandra Klooster, Clerk  
**SUBJECT:** Canada Day Entertainment

---

**RECOMMENDATION:**

THAT Council allocate \$1,535 in funds for live entertainment for our Canada Day celebrations.

---

**BACKGROUND:**

Canada Day presents a significant opportunity for our residents to come together and celebrate our nation's heritage, values, and diversity. By providing engaging live entertainment, we can enhance the events atmosphere and promote community spirit.

In 2023 \$2,500 was allocated for live entertainment which covered entertainment from 1:00pm to 9:00pm. An additional \$407.04 was used to hire a Magician to give a performance.

Based on feedback from the 2023 Canada Day celebration the Recreation Committee has made several changes for the 2024 Canada Day event.

1. That the hours of the event be shortened from 12.5 hrs. to 6.5 hrs.
2. That the fireworks display be moved to the Labour Day event

In 2024 Live entertainment has been arranged with JR Aubertin and Friends performing from 1:00pm to 3:00pm at a cost of \$600 and 60 Cycle Hum performing from 3:00pm to 5:00pm at a cost of \$500.

Additionally, children's entertainment has been arranged with Tickled Teals to provide face painting and balloon animals for a 4 hour period at a cost of \$435.

---

**FINANCIAL:**

**Canada Day:**

**1. 2023 Fireworks: \$3,653.09**

These funds would be transferred from Canada Day directly to the Labour Day event budget to cover the fireworks display at that event.



---

## REPORT TO COUNCIL

---

2. 2023 Live Music Entertainment: \$2,500  
**2024 Live Music Entertainment: \$1,100**  
\$1,400

This would allow \$1,400 in funds for Live Entertainment for our Labour Day event, which was covered by a donation last year.

3. **2024 Ballon and Face Painting Artist \$435**

**Total Canada Day 2024 Entertainment Costs:**

Live Musical Entertainment \$ 1,100.00  
Children's Entertainment \$ 435.00  
**\$ 1,535.00**

---

Respectfully,

  
\_\_\_\_\_  
Casandra Klooster  
Clerk

I concur with this report,

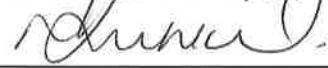
  
\_\_\_\_\_  
Nicky Kunkel  
CAO



---

## REPORT TO COUNCIL

---

**MEETING DATE:** February 27, 2024  
**TO:** Mayor and Council  
**FROM:** Ann Carr, Planning Administrator  
**SUBJECT:** Sale and Disposition of Land RE: Beath, Patrina and Jeffery

---

**RECOMMENDATION:**

WHEREAS Jeffery and Petrina Beath requested to purchase Block 21, Section 36M-516, directly abutting their property located at 16 Rock Ridge Lane, Rutherglen, AND WHERE Council approved of the purchase in "principle" at the regular meeting of Council on January 30<sup>th</sup>, 2024 AND WHERE the Planning Administrator proceeded accordingly AND FURTHERMORE the Township solicitor discovered through the Lands and Title Registry that the subject land was not transferred to the Township and therefore does not own Block 21 and cannot authorize the sale AND NOW THEREFORE unspent funds from the Beath's deposit be returned.

---

**SUBJECT LAND AND INFORMATION:**

The subject property is in the M5-16, "Olliver" Subdivision which was created in 1980. This subdivision abuts Kaibuskong Bay and Shields Point Road. Block 21 was designated in the plan of subdivision as parking for lots 1 through 9 as well as easement for Rock Ridge Lane to travel over the same on Block 22 to their properties.

After engaging the Township's solicitor, he identified through the Lands and Titles Registry that the property is still owned by the original sub-divider; Thibeault Development Limited. The Township solicitor also indicated that a Municipality believing they own lands that they do not own often occurs due to the appearance of the land and especially in this case because no tax roll number is assigned to the subject lands.

There are instances when developers end up owning lands set aside for common use by lot owners and then once the developer sells all the lots assumes the road is in new ownership and it is forgotten, or the corporation is dissolved.

When land is owned by a corporation and the corporation no longer exists (it is purposefully dissolved, or it is involuntarily dissolved because annual corporation filing requirements haven't been met) any land owned by that corporation at the time of dissolution falls into Provincial ownership. In many cases the Province doesn't want it and will accept requests to take ownership. We do not know the status of Thibeault Development Limited, but they are currently registered owners. Block 21 and Rock Ridge Lane remains private lands with no municipal jurisdiction.

---

Respectfully,

Ann Carr  
Planning Administrator

I concur with this report,

Nicky Kunkel  
CAO



---

## REPORT TO COUNCIL

---

**MEETING DATE:** February 27, 2024  
**TO:** Mayor and Council  
**FROM:** Ann Carr, Planning Administrator  
**SUBJECT:** Forming a Not-For-Profit Committee-History of Bonfield

---

**RECOMMENDATION:**

WHEREAS the Council of the Township of Bonfield understands the importance of the heritage and culture of the Township regarding the rich railway history that developed, what is now known, as the Township of Bonfield; AND WHEREAS a non-for-profit committee will be formed to preserve the history of Bonfield as well as to celebrate our heritage through objectives and goals of the committee; THEREFORE the Planning Administrator will represent the Township of Bonfield as the liaison on the committee to report back to the Council.

---

**BACKGROUND INFORMATION:**

On October 8<sup>th</sup>, 2002, the Township of Bonfield was inducted into the Canadian Railway Hall of Fame on as the historic location where the first spike was driven in the CPR Trans-Continental Railway. A celebration was held to commemorate the event. The event was to occur yearly. However, many failed attempts to move the objectives of a “first spike” committee were set to the side after the inaugural event.

During this time (2009) a study by Stan Lawler and Associates consultants was conducted to determine the most effective, efficient, and sustainable means of memorializing Bonfield’s status as the Original Eastern Terminus of the Canadian Pacific Railway.

On February 2, 2024, a meeting was held at the Township Office with Steve Philpott (Fire Up 503), Elmer Rose (unofficial Bonfield Historian), Caren Gagne, Holley Menard (Lions Club), the Township’s CAO and Planning Administrator to discuss reviving the history of the “first spike”. Minutes from the meeting are an appendix to this report.

---

**ANALYSIS:**

Preserving the history and heritage of Bonfield provides the following:

- Potential basis for local economic development and tourism.
- Defines local identity and reinforces a sense of place.
- Knowing about our past enhances our sense of “roots” and belonging.

The members of the public at the February 2, 2024, meeting act as an informal Committee working together to implement projects from the 2009 study as well as preserving the general history of Bonfield. This committee is outside of Council and are looking to incorporate as a non-profit group. Once they are incorporated the Township will be able to partner in funding opportunities. The Lawlor Study, Waterfront Plan and soon to be updated Strategic Plan offer projects that can be accomplished in partnership with each other. Connecting all the studies together creates a better opportunity for funding and a streamlined implementation process.

---

The committee has just begun the process of becoming a formal committee and more information will be available as they work through that process. The Committee would like to include a municipal representative in their meetings as many projects could be on municipal property. The role for the municipality is to be a liaison position and not intended to act as a member of the non-profit group. The Planning Administrator is a good fit for this role as the position assists the CAO with community development. This is not to be a permanent situation but certainly as, and when needed, to help implement projects that celebrate the history of Bonfield, as approved by Council.

The Committee has listed several priorities, some of which are already being completed. This includes, becoming incorporated, painting the caboose (Lions have this planned), creating a large spike and finding a central location to place it to commemorate Bonfield's history in the railway, installing highway signs to bring tourism into the community, and erecting a memory wall of the names of those that helped build the railway from the East Terminus out. The Committee is also currently working on recording Mr. Rose's historical stories and creating podcasts to share history with the community.

When speaking with Jeanette Sheilds, CEO of the Bonfield Public Library; she said that often they are asked for historical material on the Township of Bonfield. The ask is typically from new residents that have just moved here. Currently there is a book that was made during the 100<sup>th</sup> anniversary of Bonfield, however it is more of a family book of pictures and doesn't truly depict the history of Bonfield through the railway connection.

As a starting point to creating a "wall of Bonfield history", there is some room on the back hallway here in the municipal/library building to add a "picturesque wrap" of photos and excerpts of Bonfield history. Should Council agree to this, a quote for such can be provided for approval.

---

Respectfully,



Ann Carr  
Planning Administrator

I concur with this report,



Nicky Kunkel  
CAO

---

Appendix-Meeting Minutes



---

## MINUTES OF MEETING

---

**MEETING DATE:** February 02, 2024, 11:00 AM Board Room at Municipal Office

**ATTENDANCE:** Holley Menard  
Elmer Rose

Steve Philpott  
Caren Gagne

**TOWNSHIP STAFF:** Nicky Kunkel, CAO

Ann Carr, Planning Administrator

---

No formal agenda was distributed.

Elmer Rose discussed the importance of having all the historical documents and stories put together in a manner that others maybe able to learn about the history of Bonfield. He is concerned, as he gets older, that if this soon doesn't occur all will be lost.

Steve Philpott produced a list of goals and objectives that the group would like to achieve in the next 12 months:

1. A plaque from Ontario Heritage Trust to recognize Bonfield being the Eastern Terminus. (It has been applied for by the Township twice and has been denied. There is a mandate every year for the plaque and perhaps at the time it was not within the mandate)
2. Highway 17 signs to direct traffic to the site
3. A 10-foot-high spike commemorating the event.
4. A new paint job for the caboose. (Holley Menard is part of the Lions Club and indicated that the Lion's Club has already all the paint and decals to perform the work this summer)
5. A display recognizing those individuals and families that contributed to the building of the railway and the community.
6. Landscaping if required.
7. Getting Elmer's historical stories digital as well as preserving the photos and documents.
8. Retrieving the artifacts back from the Mattawa Museum.

Long Term Goals: A museum or permanent place for the artifacts, photos, and documents.

Caren Gagne suggested putting Elmer's stories as a pod cast.

The committee pondered names for the committee.

Holley Menard mentioned that the Lion's Club is responsible for the train area in Kabuskong Park and would like to be involved with the group to maintain the essence of the Caboose area.

Meeting Closed at 12:40 p.m.





## CORPORATE POLICIES AND PROCEDURES MANUAL

### Assumption of Unmaintained Municipal Roads and Private Roadways

#### 1. Policy Statement and Rationale

This policy establishes guidelines and minimum standards for unmaintained municipal roads and private roads within the Township of Bonfield required for assumption consideration.

The goal of this policy is:

- a) To ensure adherence to the relevant Official Plan policies;
- b) To avoid passing any new development/infrastructure costs to ratepayers of the municipality;
- c) To ensure that proponents upgrading existing private roads or unassumed roads to municipal roads abide by a minimum municipal standard; and
- d) To control the means by which the Municipality may assume unmaintained municipal roads and private roads to provide fairness and consistency.

#### 2. Scope

The Township of Bonfield shall only consider through this policy the assumption of existing unassumed municipal roads or existing private roads. The policy may also consider roads within an existing plan of subdivision that were not previously assumed by the Municipality. The policy shall not be used to consider the assumption of new roads where assumption is governed by the Subdivision Agreement. If the Subdivision Agreement has been frustrated so that assumption can no longer be affected through that agreement, this policy may apply. The policy shall not be used to consider the assumption of roadways subject to a Plan of Condominium.

#### 3. Definitions

- a) "Council" shall mean the municipal Council of The Corporation of the Township of Bonfield.
- b) "Manager" shall mean either the Manager of Public Works or their designate.
- c) "Municipality" shall mean the Corporation of the Township of Bonfield.
- d) "Municipal Roads" shall mean roads and highways in municipal ownership and that have been assumed by the municipality for year-round maintenance by the municipality.
- e) "Private Roads" shall mean roads and lanes in private ownership that have not been assumed by the municipality which provide access to properties and may also be by means of a registered right-of-way to private property and the use and maintenance of which is the responsibility of the abutting landowners.
- f) "Proponents" shall mean developers, residents, or ratepayers or other associations who are requesting the municipality assume for maintenance purposes an existing private road or unassumed road so that it becomes a municipal road.
- g) "Unassumed Road" shall mean roads that are owned by the municipality that are not maintained on a year-round basis.



## CORPORATE POLICIES AND PROCEDURES MANUAL

### Assumption of Unmaintained Municipal Roads and Private Roadways

#### Policy

When submitting a proposal to the Municipality, all documentation and information must satisfy Council that the assumption of the road is in the public interest, and that the proponent acknowledges and accepts that any and all costs associated with such assumption are to be borne by the proponent, and the following procedures applied.

#### Criteria for Assumption

Without being necessarily limited to the following, the following criteria should be considered in determining if it is in the public interest to assume unassumed roads or private roads:

- a) Does the road serve, or will it serve, five (5) or more separate and distinct private parcels of land which are being used, or are capable of being used for the purposes permitted within that zone, on a year-round basis?
- b) Does the road provide access to a municipal-maintained boat launch, beach or other facility or attraction promoted by the Municipality for public use and tourism?
- c) Would the assumption of the road over-extend existing municipal road maintenance programs, operations, and resources?
- d) Was the road constructed to the standards as stated herein, thus avoiding costly future upgrades and/or repair costs to the Municipality?
- e) Will the assumption of the road promote further desired development?
- f) Would further development require the road to be extended?
- g) Would further development on the road over-extend existing municipal services?
- h) Would the road facilitate the safe and efficient movement of goods and people?
- i) For unassumed roads, at least two-thirds of all property owners representing at least one-half (50%) of the value of the lots who will receive direct benefit from the assumption of the road agree to the undertaking of the study and the assumption of the unassumed road by the Municipality. For private roads, 100% of all property owners must agree to the undertaking of the study and the assumption of the private road by the Municipality.
- j) All property owners required to give up ownership of legal title to the road and to land required for road widenings or turnarounds have consented to the Municipality's acquisition of their lands.
- k) Has the Conservation Authority or the Ministry of Natural Resources and Forestry, whichever has jurisdiction, been notified and are regulations followed where there could be any interference with wetlands or any alterations to shorelines and watercourses?
- l) Where applicable, does the Ministry of Transportation support the proposed assumption by the Municipality?



## CORPORATE POLICIES AND PROCEDURES MANUAL

### Assumption of Unmaintained Municipal Roads and Private Roadways

- m) The proposal conforms to the land use policies of the relevant Official Plan and Zoning By-law if lot creation would occur as a result of the assumption process.
- n) There is a reference plan prepared by an Ontario Land Surveyor documenting the lands affected by the proposed assumption.
- o) The proponent has provided original deeds and certification of title for the lands in question, prepared by the proponent's solicitor.
- p) The Municipality has received a legal opinion on the ownership status of the subject road and a risk assessment of assuming or not assuming the road.

### Proponent Responsibilities

- a) The cost and associated process of bringing the road up to municipal standard will be the responsibility of the proponents. Options will be provided to the proponents for immediate payment or the option to pay over a period of time as permitted under O. Reg 586/06 Local Improvement Charges – Priority Lien Status.
- b) Where the proposed right-of-way has a deficient width, all benefitting owners will be required to provide the necessary right-of-way and road widening to the Municipality free and clear of all encumbrances and at no cost to the Township of Bonfield.
- c) Where the proposed right-of-way dead-ends and a turnaround is thus required, title to the land required for the turnaround must be transferred to the Municipality at no cost to the Municipality.
- d) Prior to the commencement of an engineering study, the proponent shall submit to the Municipality a refundable deposit of one thousand dollars (\$1,000.00 CAD). The Chief Administrative Officer, Manager of Public Works, Municipal Engineer, or their designate will provide the proponent with an estimate and additional deposit may be required prior to proceeding. This deposit will be used to cover the engineering review costs and the amount may be increased as needed if the review is more complex. Any amount of the deposit not needed to cover the independent review will be returned to the Proponent.

### Staff Responsibilities

- a) Upon receipt of a petition requesting assumption of a roadway, municipal staff will verify the sufficiency of the petition i.e. petitions not supported by two-thirds of the property owners adjacent to the roadway will not be considered, petitions not supported by all owners giving up title rights will not be considered, and assumption of portions of a road less than 500 meters will not be considered unless the road links existing maintained municipal roads.
- b) Municipal staff will prepare a Council Report and if Council agrees "in principle" with





## CORPORATE POLICIES AND PROCEDURES MANUAL

### Assumption of Unmaintained Municipal Roads and Private Roadways

- the possible assumption of the road then the works will proceed following confirmation of financing methodology.
- c) Prior to assuming the road, the Municipality shall request an independent review of the subject road, at the Proponent's expense. This review will include a report on the as-built condition of the existing road by a professional engineer and a cost-benefit analysis to determine the operational costs of maintaining the road and the impact on municipal resources. In addition, the consultant will prepare, as part of the engineering report, an estimate of all costs relating to the construction or reconstruction of the unassumed road to the standards as stated herein. The cost of the independent engineering review and cost-benefit analysis will be borne by the Proponents.
  - d) Year-round road service will not be provided on private roads until Council passes a by-law to formally assume the road and until the subject road is upgraded to the road standards as detailed in Appendix "A" to this policy.
  - e) If assumption of a privately-owned road is requested, and where acquisition by the Municipality will result in severance(s), the Chief Administrative Officer will be invited to comment to any Committee that convenes to consider the acquisition and assumption. The Planning Department will consider the implications of the road assumption to ensure that any natural severances conform to the Official Plan policies and Zoning By-law regulations.
  - g) Any formal requests and petitions for road assumption received after August 31st in any year will not be considered until the following year to avoid unreasonable demands on the Municipality's winter control operations.
  - h) The assumption of roads may be implemented through a Site Plan and/or Development Agreement to the satisfaction of the Public Works Manager & Engineer. The Agreement will include the approved drawings, cost estimates, and securities for the proposed road works.

### Municipal Road Standards

Appendix "A" to this policy provides specifics for the Minimum Road Construction Standards that must be met prior to the assumption of any unmaintained municipal road or private road.

Road improvement and work necessary to bring a road up to the standards listed in Appendix "A" may include property acquisition for road allowance widening and/or turnarounds, tree removal, road base and/or surface improvement, drainage improvement, horizontal and vertical alignment improvements, removal of encroachments and signage installation.

## CORPORATE POLICIES AND PROCEDURES MANUAL

### Assumption of Unmaintained Municipal Roads and Private Roadways

#### Appendix "A"

#### Road Standards for Adoption of Rural Roads

<u>Design Criteria</u>	<u>Minimum Standard</u>
Right of Way Width	20.0
Design Speed	60 km/hr
Posted Speed	40 km/hr
Horizontal Radius	60.0m*
Maximum Grade	8.00%
Minimum Grade	0.5%
Kcrest	15
Ksag	18
Min Stopping Sight Dist	85.0 m
Min Number of Lanes	2
Lane Width	3.35 m
Shoulder Width	1.0 m
Platform Widening	OPSD 209.010, OPSD 200.010, OPSS 206
Horizontal Clearance	3.0 m
Vertical Clearance	5.25 m
Turn Arounds	OPSD 500.01 or equivalent
Granular Surface	150 mm Granular 'A'
Granular Base	400 mm Granular 'B'
Surface Type (ADT < 400 vpd)	Gravel
Surface Type (ADT > 400 vpd)	60mm Superpave 12.5 PGAC 58-34
Compaction	OPSS.MUNI 501
Signage	As specified in the Ontario Traffic Manual
Drainage	Ditches to be 300mm below granular base and outletting to and adequate receiving watercourse
Streetlights	At discretion of Engineer

#### Notes:

- 1 Deviations from the minimum standard may be approved by the Public Work Manager and Engineer, where the minimum standards cannot be achieved. The deviation must not result in any significant loss of safety or increased maintenance costs to the municipality.
- 2 The standards detailed above apply only to the assumption of private roads or roads constructed on unopened road allowances and are not the standards applicable to new construction after the date of the adoption of the standard by Municipal Council.



## **CORPORATE POLICIES AND PROCEDURES MANUAL**

### **Assumption of Unmaintained Municipal Roads and Private Roadways**

#### **Definitions**

Kcrest – Road design factor for a vertical curve which when viewed from the side is convex upwards. ie. A hill

Ksag – Road design factor for a vertical curve which when viewed from the side is concave upwards. ie. A valley

ADT – Average Daily Traffic

Vpd – vehicles per day

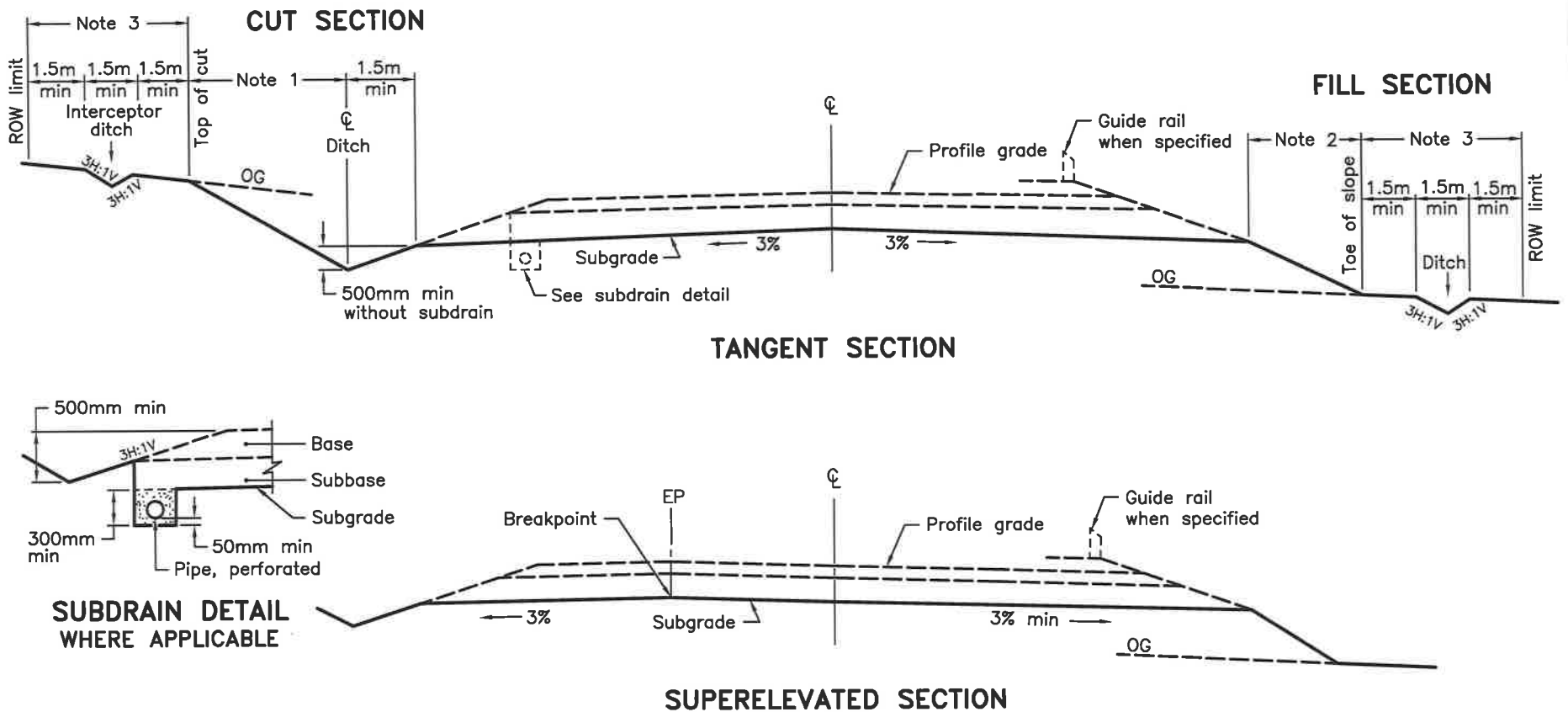

**NOTES:**

- 1 Cut slope shall be 3H:1V or steeper when specified.
- 2 Fill slope shall be 3H:1V or flatter when specified.
- 3 Distance shall be 1.5m minimum when ditch is not required.

A This OPSD to be read in conjunction with OPSD 202.010 and OPSD 202.020.

B All dimensions are in metres unless otherwise shown.

ONTARIO PROVINCIAL STANDARD DRAWING		Nov 2009	Rev 2	
<b>EARTH/SHALE GRADING</b> UNDIVIDED RURAL				
<b>OPSD 200.010</b>				

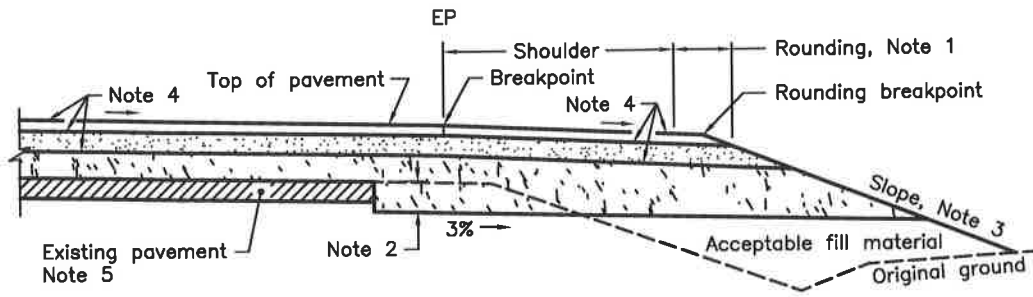

**TYPE 1  
HALF GRADING SECTION  
HOT MIX WITH GRANULAR GRADE RAISE**

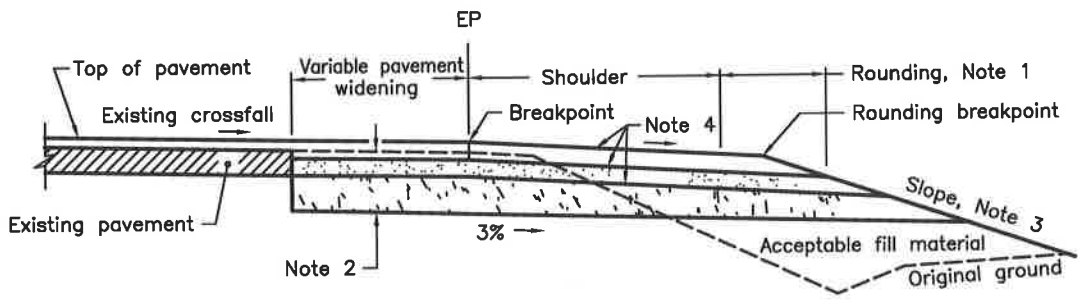

**TYPE 2  
HALF GRADING SECTION  
RESURFACING AND GRANULAR WIDENING**

**LEGEND:**

-  Granular base
-  Granular subbase

**NOTES:**

- 1 Rounding shall be 0.5m or greater when specified.
  - 2 Depth of excavation shall be as specified, and should be equal to or lower than existing subgrade.
  - 3 Slope shall be as specified.
  - 4 Crossfall shall be as specified.
  - 5 Existing pavement under granular grade raise shall be removed, processed, or left in-place, as specified.
- A This OPSD to be read in conjunction with OPSD 208.010.  
 B All dimensions are in metres unless otherwise shown.

ONTARIO PROVINCIAL STANDARD DRAWING	Nov 2018	Rev 2	
<b>RURAL PAVEMENT WIDENING</b>			
OPSD 209.010			

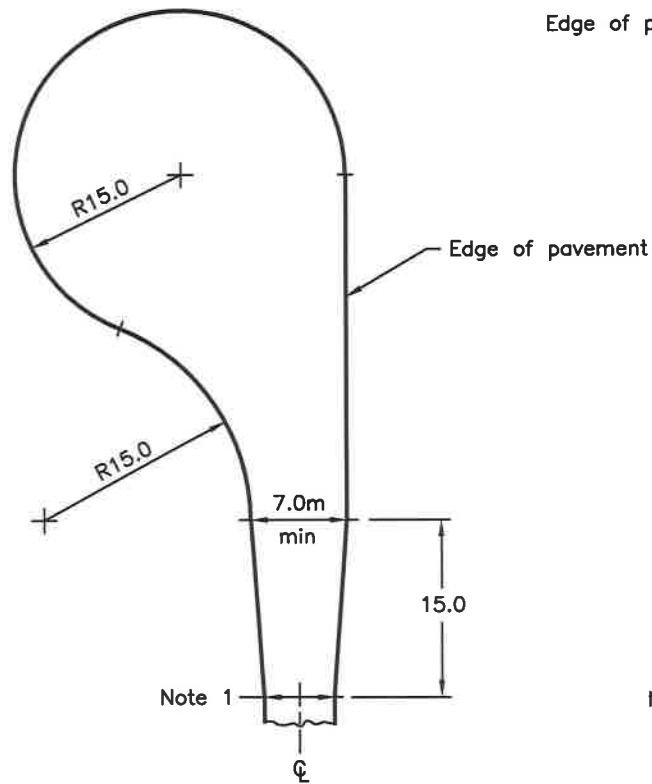

**TYPE A**

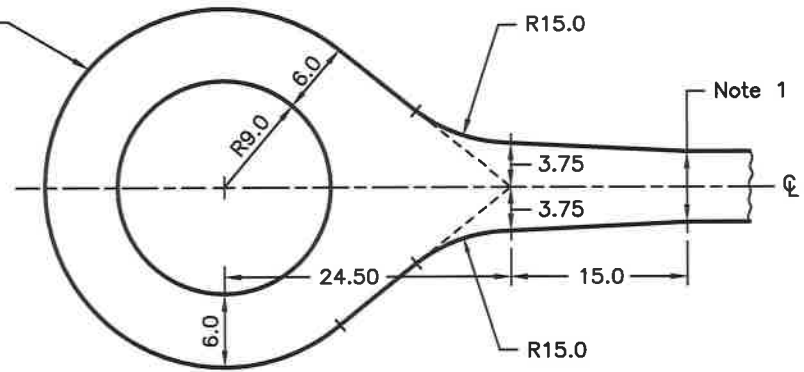

**TYPE B**

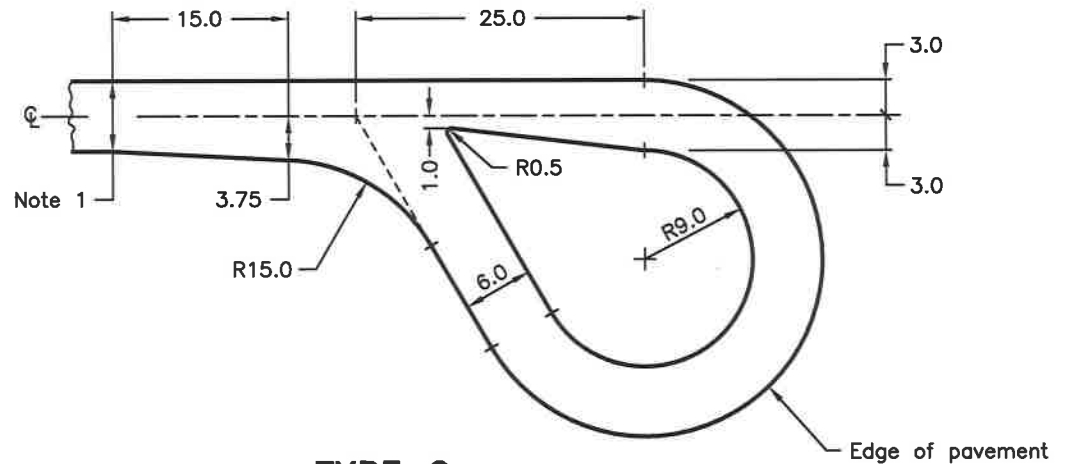

**TYPE C**

**NOTES:**

- 1 Width of pavement, shoulder, and rounding to match terminated roadway.
- A Drainage and grading as specified.
- B All dimensions are in metres unless otherwise shown.

ONTARIO PROVINCIAL STANDARD DRAWING	Nov 2018	Rev 1	
<b>TURNING BASINS FOR TERMINATED RURAL ROADWAYS</b>			
<b>OPSD 500.010</b>			

---

## REPORT TO COUNCIL

---

**MEETING DATE:** February 27, 2024  
**TO:** Mayor and Council  
**FROM:** Nicky Kunkel, CAO Clerk-Treasurer  
**SUBJECT:** User Fees

---

### RECOMMENDATION:

That the Council for the Township of Bonfield authorizes staff to work on an updated user fee by-law for consideration in March.

---

### BACKGROUND INFORMATION:

In reviewing current policies, procedures and by-laws it is noted that the user fees charged by the Township have not been renewed since 2012 except for planning and building in 2016. The newest user fee by-law 2016-19 is eight (8) years behind.

User fees are permitted through various legislated acts, including the Municipal Act, the Planning Act, the Fire Prevention Act to name a few. User fees are used as an alternative to increasing taxation. They are charged for goods and services where it can be determined that the service only benefits the user. They are mandated to be cost recovery only and are not meant to be used as a revenue source.

An example, currently the Township includes 104 free garbage bags per year as a right to dump at the landfill site. The limit is in place to keep the volume of waste low, so the landfill site has a longer life, and it encourages recycling. However, there are users who do not recycle and have more than the allocated number of free bags. Those users are charged an additional \$2.00 per bag over their limit as they use more of the landfill site than others. The \$2.00 a bag is the user fee.

Other types of user fees are planning applications, building permits, tax certificates, photocopies, and fire inspections. The fees are approved by Council through by-laws.

---

### ANALYSIS:

In reviewing the current by-laws there are fees that are not covering the cost to provide the service.

For example, the fee for an entrance permit is \$30.00. This should cover the cost of the site visit, the review of the application, and the issuance of the permit which is closer to \$50.00. The fee should also have a deposit requirement so that if there is any road damage when installing the entrance, it is the property owner who covers that cost and not the whole of the ratepayers. When a new home is built there can be anywhere from 50 to 300 heavy trucks that enter the property and

---

this tends to damage the road. Sometimes it is minor and other times it can require cold patching or asphalt repairs. If it is not repaired in a timely manner the road will further deteriorate. Having the deposit will ensure the repair is completed and any unused funds would be returned to the owner.

Also, the current fee for the civic address/911 sign is \$30.00, set in 2012. The cost to purchase the sign with the post is now \$55.00 per sign. The Township is not recovering the costs for individual property owners and the tax levy is picking up the tab for the difference. While this is not a high-volume service and has a minimal impact, the fee should be increased to cost recovery.

Currently, the Township does not charge for dog tags. However, there is a by-law that requires dog owners to have a tag. The practice is that staff mail a letter with the tag to all known dog owners each year, about 100 per year. This is done free of charge. However, the costs to do this is approximately \$18.00 per tag. There should be a fee applied to the dog tag. Again, while not a significant impact to the tax levy pet ownership should not be a communal expense.

Another fee to implement would be for fire permits. Currently the Township does not issue fire permits but there are requests for special day time burning. Working with the Fire Chief, this could be a service that is implemented with a fee. In issuing the permit the Township would need to confirm that there are fire staff available should there be an incident. Also, issuing permits for fires would require a homeowner to sign off that they understand the rules of lighting a fire and have the necessary precautions in place to avoid the fire getting out of control. With the increase in forest fires, it is imperative that property owners are more aware of their surroundings and having to read and sign off on a permit would achieve this goal. A user fee could be \$20.00 a year during the fire season (April to November) or \$20.00 for a four-day-to-one-week special day burning permit for those that are clearing lots. It's a small fee that would allow officials to better determine costs but be manageable for residents.

Staff did a fee comparison in 2022 and those results are emailed to you in a separate excel spreadsheet for your review. It does indicate the fees of 2012 have not kept up with costs or general standards for similar fees.

I recommend that Council authorize staff to present a draft user fee by-law for consideration in March of 2024. The Municipal Act states that there must be a public meeting prior to Council implementing any fees so there is a minimum of two Council meetings prior to the fees being enacted.

---

Respectfully,  
Nicky Kunkel





THE CORPORATION OF THE TOWNSHIP OF BONFIELD  
Emergency Services Committee Meeting  
February 12<sup>th</sup>, 2024 at 6:00 pm

PRESENT: Steve Featherstone, Chair  
Donna Clark, Vice-Chair  
Gilles Lebel, Fire Chief  
Dave Vieira, Deputy Fire Chief

STAFF: Santana Chubb, Clerk

EXCUSED ABSENCE: Allan Reid, CEMC

**1. Call to Order**

Moved by Donna Clark  
Seconded by Dave Vieira

THAT the Emergency Services Committee meeting be opened at 6:03 p.m.

**Carried Chair, Steve Featherstone**

**2. Adoption of the Agenda**

Moved by Donna Clark  
Seconded by Dave Vieira

THAT the agenda for the Emergency Services Committee meeting for February 12, 2024, be approved as circulated.

**Carried Chair, Steve Featherstone**

**3. Adoption of the Minutes**

Moved by Donna Clark  
Seconded by Dave Vieira

THAT the minutes of the Emergency Services Committee meeting held January 15, 2024, be adopted as circulated.

**Carried Chair, Steve Featherstone**

**4. Disclosure of Pecuniary Interest and General Nature Thereof**

None for this session

**5. Delegations and Presentations**

None for this session

## **6. Correspondence and Information**

### **6.1 Information re calls and Fire Department activities provided by Gilles.**

- Attended 1 medical call
- Attended 1 structure fire

## **7. New Business**

### **7.1 Cell Phone Policy**

- The Fire Chief and Deputy Fire Chief were reminded to be mindful of data usage on their phones due to going over data limits in January. It was the first time it's happened, but different data plans can be looked at if it becomes a reoccurring issue.

## **8. Unfinished Business**

### **8.1 SCBA Equipment Replacement Update**

- The Deputy Fire Chief is waiting to receive the third and final quote for the required equipment. It should be received this week and will be presented to the CAO.

### **8.2 2024 Task List Provided by CAO - Update**

- The Fire Department has started working on the task list.
- It was requested by the Chair and Vice-Chair that a progress report be presented at the next meeting.

## **9. Community Risk Assessment**

### **9.1 Community Risk Assessment Update**

- The Fire Chief presented to the committee his completed section of the CRA that was due by the end of February.
- The next step will be for the CEMC to review the work sheets and assemble the final CRA to be presented for final review.

## **10. Public Events/ Public Education**

### **10.1 Hockey Tournament**

- Due to mild weather and lack of ice, the hockey tournament has been called off.
- There are no other events planned for February.

## **11. Training**

### **11.1 Training Nights**

- At tonight's weekly volunteer meeting (Monday, February 12<sup>th</sup>), the volunteers are going through IMS training, provided by one of Bonfield's qualified volunteer fire fighters.
- The volunteers are studying every week for their Fire Fighter 1 and 2 certifications.

### **11.2 Bush Fire Training**

- A bush fire training course is being planned for April or May.
- The course costs \$6500.00 for the weekend and requires a minimum of 15 participants.
- It was recommended by the Chair and Vice-Chair to open the training course to the surrounding municipalities' Fire Departments.
- The Committee discussed the possibility of bringing in an instructor to speed up the training process to complete the Fire Fighter 1 and 2 training.

**12. Addendum**

None for this session.

**13. Adjournment**

**Moved by** Donna Clark

**Seconded by** Dave Vieira

THAT this meeting be adjourned at 6:26 p.m.

**Carried Chair, Steve Featherstone**

The next scheduled meetings are:

- March 18<sup>th</sup>, 6:00 p.m.
- April 15<sup>th</sup>, 6:00 p.m.

---

CHAIR

---

SECRETARY

**THE CORPORATION OF THE TOWNSHIP OF BONFIELD**

**BY-LAW NO. 2024-10**

Being a by-law to enter into an agreement with the North Bay and District Humane Society for the provision of animal control services in the Township of Bonfield

**WHEREAS** the Council of the Township of Bonfield wishes to provide professional animal control services, as defined by Bonfield By-Law 2013-09, to the residents of the Township of Bonfield;

**AND WHEREAS** the North Bay and District Humane Society currently provides professional animal control services to several municipalities in the District of Nipissing;

**NOW THEREFORE** the Council of the Corporation of the Township of Bonfield hereby enacts as follows:

1. **THAT** the attached 9-month agreement for Animal Control Services between the Township of Bonfield and the North Bay and District Humane Society, is hereby accepted and attached as Schedule "A" to this By-Law; and
2. **THAT** the Mayor and Clerk be hereby authorized to execute this Agreement on behalf of the Corporation of the Township of Bonfield; and
3. **THAT** this by-law shall come into force and take effect upon the passing thereof.

READ A FIRST, SECOND AND THIRD TIME AND FINALLY PASSED THIS 27TH DAY OF FEBRUARY 2024.

---

MAYOR

---

CLERK

**SERVICE CONTRACT AGREEMENT BETWEEN:  
THE NORTH BAY AND DISTRICT HUMANE SOCIETY  
AND THE  
TOWNSHIP OF BONFIELD**

The following outlines an agreement for the North Bay and District Humane Society to provide pound keeping services for the Township of Bonfield. Further this agreement defines other services provided; specifically animal control, site patrols, as well as the enforcement of various animal control By-laws enacted by the Township of Bonfield.

**1. DEFINITIONS:**

For the purpose of this Agreement, the term “animal” shall refer to domestic dogs, and cats.

For the purpose of this Agreement, the North Bay and District Humane Society will be referred to as “NB&DHS”.

For the purpose of this Agreement, the Township of Bonfield will be referred to as “the Township”.

**2. THE HUMANE SOCIETY AGREES:**

Shelter:

To provide an animal shelter capable of providing adequate accommodations, food and water, daily housekeeping and veterinary care (when deemed necessary) for animals impounded, and of meeting the requirements set for this type of building by the NB&DHS, and of meeting the requirements of all applicable provincial legislation.

By-laws:

To enforce all By-laws affecting the control and keeping of animals, as adopted and amended from time to time, excluding any provisions pertaining to the proper care of animals & dangerous animals.

Officer:

To employ and supervise such Animal Control Officer(s) as may be considered necessary and to provide such Officer(s) with adequate vehicle(s), safety equipment, uniforms and communications equipment and to pay all costs of such Officer(s) and vehicle(s), safety equipment, uniforms and communications equipment as provided by NB&DHS.

### General Service Provision:

- a) To provide pound services.
- b) To hold for claiming by owners, any stray animal delivered to the NB&DHS shelter or any animal received or impounded by the Animal Control Officer, and, if not claimed by the owner, to dispose of such animal by sale or euthanasia. Owners of licensed and/or microchipped dogs and cats will be contacted, whenever possible.
- c) To provide an animal shelter capable of providing adequate accommodations, food and water, daily housekeeping and veterinary care (when deemed necessary) for animals impounded.
- d) To meet the requirements set for this type of building by the NB&DHS and Provincial legislation.
- e) To install in the animal shelter all the equipment necessary for the proper operation of the animal shelter, and, in particular, to supply the methods and equipment necessary to humanely euthanize unwanted or unclaimed animals, if necessary. Such methods and equipment must meet the standards and comply with the applicable Provincial legislation.

### Fee for Service Provision:

- a) Monday to Friday (exclusive of statutory holidays) an officer will be available, and as dictated by priority, to the Township area from 9:00am to 4:30pm to respond to complaints of animals at large, stray animals, and By-law infractions only if the animal is humanely confined, either by being in a building, crate, cage, box, or tethered safely.
  - *The NB&DHS will endeavour to dispatch its staff in the most efficient and cost effective manner possible as dictated by demand.*
- b) Emergency services will be provided for a fee as outlined in Schedule 1 Monday to Friday from 4:30pm to 9:00am and on weekends.
  - *Emergency services are comprised of injured dogs and cats that are at large where an owner cannot be found and requests for assistance by police services that pertain to animal issues.*

### Hours of Operation:

The NB&DHS shelter will be open to the public and in operation between 10:00am and 5:00pm Monday to Friday (exclusive of statutory holidays), between 10:00am and 4:00pm Saturdays, and between 12:00pm and 4:00pm Sundays. Hours of Operation may change at the discretion of the NB&DHS.

It is understood by the Township and the NB&DHS that ALL calls reporting complaints or concerns from residents of the Township will be forwarded to the Animal Control Officer of the Township.

### Licenses:

- a) To license animals according to procedures approved by the Township and the NB&DHS.
- b) To not release any impounded animal until such animal is licensed.

### Records:

To submit to the Township, quarterly as of the end of December, a written summary of the statistics pertaining to the Township including (but not limited to):

- i. Number of animals impounded
- ii. Disposition of animals impounded (ie. claimed, euthanized, rehomed)
- iii. Total number of licenses issued

### Indemnity:

To indemnify and save harmless the Township in respect to all charges, costs, expenses, suits, and damages, and claims for loss or accident or injury of any nature or kind whatsoever in connection with the carrying out of this agreement and in connection with the shelter.

### Insurance:

To insure and keep insured the shelter building for fire and any other hazards and to provide, if required, the Township a proof of insurance.

Such liability policy shall provide for the indemnification of the Township and the NB&DHS against the loss arising from claims of damage, injury or otherwise in connection with the carrying out of the terms of this agreement.

The NB&DHS shall maintain the policy of insurance in force during this agreement. The limits of such policy shall not be less than One Million Dollars (\$5,000,000.00) inclusive for public liability and property damage and for liability coverage for injury to animals

caused by an accident and resulting in the death or destruction while in the care, custody and control of the NB&DHS.

Such policy shall include the names of the Township and the NB&DHS as the insured.

The Humane Society shall pay the premium on the policy.

**3. THE TOWNSHIP OF BONFIELD AGREES:**

- a) To appoint the NB&DHS as Pound Keeper and Animal Control Officer for the Township of Bonfield with the duties of such Pound Keeper and Animal Control Officer to be exercised by the NB&DHS to pick up and impound animals in accordance with the provisions of the By-laws.
- b) To appoint the NB&DHS's Animal Control Officer(s) as Provincial Offences Officer(s) pursuant to the Provincial Offences Act and delegations made there under.
- c) To grant the NB&DHS the right to dispose of all animals impounded by the Humane Society in accordance with the By-laws.
- d) To grant the NB&DHS the right to dispose of the carcasses of all animals lawfully impounded and lawfully euthanized or found dead in accordance with the By-laws.
- e) To grant the NB&DHS the right to collect impound fees, fines, destruction, and disposal fees levied by the NB&DHS in accordance with the scale of fees and penalties authorized by the NB&DHS and including all license fees both by the Township and the NB&DHS.
- f) To pay the NB&DHS remuneration for its services as Pound Keeper as follows:  
April 1st 2024 to December 31st 2024 - \$9,180.00 exclusive of HST

**4. DURATION OF AGREEMENT:**

The term of the agreement will be one (9) months commencing April 1<sup>st</sup> 2024.

This agreement may be terminated by either party upon three (3) months written notice of intention to terminate, delivered to the other party by prepaid registered mail.



This agreement is made on the \_\_\_\_\_ day of \_\_\_\_\_, 20\_\_\_\_.

FOR THE TOWNSHIP OF BONFIELD:

Name: \_\_\_\_\_

Title: \_\_\_\_\_

Signature: \_\_\_\_\_

Name: \_\_\_\_\_

Title: \_\_\_\_\_

Signature: \_\_\_\_\_

FOR THE NORTH BAY AND DISTRICT HUMANE SOCIETY:

\_\_\_\_\_  
Jodi Steeves  
President of the Board of Directors

\_\_\_\_\_  
Liam Cullin  
Executive Director

## **Schedule 1 – Fee for Service**

The following schedule outlines the fees charged to the Township by the NB&DHS for emergency services as outlined in the agreement.

### After Hours & Emergency Fees:

- **Staff & General Overhead Fees:** \$110.00 per hour (from departure to return)
- **Vehicle Fees:** \$0.55 per kilometer (from departure to return)

**THE CORPORATION OF THE TOWNSHIP OF BONFIELD  
BY-LAW NO. 2024-12**

Being a By-law to stop up, close and sell part of the Original Shore Road Allowance in Front of Part Lot 3, Concession 6, being Part 1, 36R15133, Township of Bonfield, District of Nipissing

(Thompson)

---

**LEGISLATION**

**WHEREAS:**

1. pursuant to Section 27(1) of the *Municipal Act, S.O. 2001, c.25*, as amended, municipalities are given authority over highways within their jurisdiction;
2. the Original Shore Road Allowance which is the subject matter of this by-law is within the jurisdiction of this municipality.

**AND WHEREAS** pursuant to the Municipality's Policies and Procedures for the Closure and Sale of Road Allowances, this Corporation did cause a Notice of the proposed By-law to be published and posted.

**BE IT ENACTED AS A BY-LAW OF THIS CORPORATION AS FOLLOWS:**

1. Stop Up and Close - Original Shore Road Allowance - This Council does hereby stop up and close to vehicular and pedestrian traffic the lands described in Schedule "A" attached.
2. Surplus Property - The said lands described in Schedule "A" are declared to be surplus to the requirements of this Municipality.
3. Authorization for Sale - This Council does hereby authorize the sale of the said lands for a consideration of \$1,800.00 plus H.S.T.
4. Easements - This Council does hereby authorize the transfer of such easements over the lands described in Schedule "A" attached hereto as required by utility providers, prior to conveyance to the abutting owner. Notice of the proposed road closings were sent to Hydro One Networks Inc., Bell Canada and Public Works Canada. All have responded that they do not have any easement requirements.
5. Sale of Land By-law - Compliance with the Notice provisions of By-law 2016-07, will be deemed to be compliance with the Notice provisions of this Municipality's Sale of Land By-Law 2013-13.
6. Clerk's Affidavit - There shall be attached to this By-law, as Schedule "B", an affidavit by the Clerk of this Corporation, setting out:
  - a) the procedures taken for the giving of Notice pursuant to By-law 2016-07; and,
  - b) the procedures taken for notice to Public Utilities and applicable Government Departments or Ministries.
7. Clerk's Compliance - There shall be included in the Clerk's Affidavit a statement affirming that the procedures taken by the Township are in compliance with By-law 2013-13.

READ A FIRST, SECOND, THIRD TIME AND FINALLY PASSED THIS 27th DAY OF FEBRUARY, 2024.

**THE CORPORATION OF THE  
TOWNSHIP OF BONFIELD**

---

Narry Paquette, Mayor

c/s

---

Nicole Kunkel, CAO/Clerk

SCHEDULE "A"

Part of the Original Shore Road Allowance in Front of Part Lot 3, Concession 6, being Part 1, 36R15133, Township of Bonfield, District of Nipissing

---

BY-LAW CERTIFICATION

CERTIFIED to be a true copy of By-law 2024-12, and that such By-law is in full force and effect.

Dated at the Township of Bonfield, this the 27th day of February, 2024.

\_\_\_\_\_  
Nicole Kunkel, CAO/Clerk c/s

BY-LAW 2024-12  
SCHEDULE "B"

THIS IS SCHEDULE "B" TO BY-LAW 2024-12 FOR THE CORPORATION OF THE TOWNSHIP OF BONFIELD.

CLERK'S AFFIDAVIT

I, Nicole Kunkel, Chief Administrative Officer and Clerk of the Township of Bonfield, make oath and say as follows:

1. This Deponent  
I am the Chief Administrative Officer and Clerk of the Corporation of the Township of Bonfield and as such have knowledge of the facts hereinafter deposed to.
2. Publication and Posting  
Pursuant to By-law 2016-07, I did cause notice of the proposed by-law by the Corporation to stop up, close and sell that parcel of land described in Schedule "A" of By-law 2024-12:
  - (a) Publication - To be published in Community Voices (North Bay Nugget), a newspaper of local circulation, notice that the Township proposed to pass the subject By-law;
  - (b) Posting - Did post notice of the proposed By-law on site for at least two weeks before the meeting in two of the public places in the immediate neighborhood of the proposed closure;
  - (c) Posting - did post notice of the proposed By-law in the Municipal Office;
  - (d) Website - Did post notice of the said By-law on the Township Website for at least the two week period preceding the meeting in which the By-law was presented;
  - (e) Notice contained the information required by By-law 2016-07.
3. Copy of Notice  
Attached to this my Affidavit as Exhibit "A" is a copy of the actual Public Notice as it appeared in Community Voices (North Bay Nugget) and as posted.
4. Additional Notification  
Notice of the proposed road closing was sent to Hydro One Networks Inc., Bell Canada and Public Works Canada. They responded that they do not have easement interest in the subject areas.
5. Procedure  
To the best of my knowledge the closing and selling procedures taken by this Township have been in accordance with Procedure By-law 2013-13.
6. Public Attendance  
The proposed by-law came before Council at its regular meeting on the 27th day of February, 2024 and at that time, no person made any claim that the effect of the By-law would be to deprive them of the right of motor vehicle access to or from their land, and that all persons who applied to be heard, were heard.

SWORN before me at the                    )  
Township of Bonfield                    )  
this the                    day                    )  
of \_\_\_\_\_, 2024.                    )

\_\_\_\_\_  
Nicole Kunkel, CAO/Clerk

A Commissioner for taking Affidavits, etc.  
Title: \_\_\_\_\_

BY-LAW 2024-12  
EXHIBIT "A"

This is Exhibit "A" to the Affidavit of Nicole Kunkel, Chief Administrative Officer and Clerk of The Corporation of the Township of Bonfield.

**Community Voices (North Bay Nugget)**

**THE CORPORATION OF THE TOWNSHIP OF BONFIELD**

**PUBLIC NOTICE**

**RE:** Closing of Part of the Original Shore Road Allowance in front of Part Lot 3, Concession 6, being Part 1, 42R15133, Township of Bonfield, District of Nipissing.

(Thompson)

**TAKE NOTICE** that pursuant to Sections 34 and 270 of the *Municipal Act, 2001* and policies adopted by Council thereunder, the Council of the Corporation of the Township of Bonfield proposes to enact a by-law to stop up, close and sell part of the following road allowances:

Part of the Original Shore Road Allowance in front of Part Lot 3, Concession 6, being Part 1, 42R15133, Township of Bonfield, District of Nipissing.

**AND TAKE FURTHER NOTICE THAT** the proposed by-law will come before Council of the Township of Bonfield at its regular meeting at the Township office at 365 Highway 531, Bonfield on the 27<sup>th</sup> day of February 2024 at 7:00 p.m.

**AND FURTHER TAKE NOTICE** that Council will consider comments from anyone in person, or by his/her counsel, solicitor or agent, at the foregoing meeting or, who in advance of the meeting, submits written comments to the Planning Administrator at the address listed below.

**PLAN 36R-15133** is available for inspection at the Township offices.

**DATED** at the Township of Bonfield, this the 08th day of February 2024.

Ann Carr, Planning Administrator  
Township of Bonfield  
365 Highway 531  
Bonfield, Ontario  
POH 1E0

*This is Exhibit 'A' mentioned and referred to in the Affidavit of Nicole Kunkel.*

*SWORN before me this \_\_\_\_\_ day of \_\_\_\_\_, 2024.*

\_\_\_\_\_  
*A Commissioner for Taking Affidavits, etc.*

*Title: \_\_\_\_\_*

**THE CORPORATION OF THE TOWNSHIP OF BONFIELD  
BY-LAW NO. 2024-13**

Being a By-law to stop up, close and sell part of the Original Shore Road Allowance in Front of Lot 2, Concession 7 being Part 1, 36R15069, Township of Bonfield, District of Nipissing

(Fleckney)

---

**LEGISLATION**

**WHEREAS:**

1. pursuant to Section 27(1) of the *Municipal Act, S.O. 2001, c.25*, as amended, municipalities are given authority over highways within their jurisdiction;
2. the Original Shore Road Allowance which is the subject matter of this by-law is within the jurisdiction of this municipality.

**AND WHEREAS** pursuant to the Municipality's Policies and Procedures for the Closure and Sale of Road Allowances, this Corporation did cause a Notice of the proposed By-law to be published and posted.

**BE IT ENACTED AS A BY-LAW OF THIS CORPORATION AS FOLLOWS:**

1. Stop Up and Close - Original Shore Road Allowance - This Council does hereby stop up and close to vehicular and pedestrian traffic the lands described in Schedule "A" attached.
2. Surplus Property - The said lands described in Schedule "A" are declared to be surplus to the requirements of this Municipality.
3. Authorization for Sale - This Council does hereby authorize the sale of the said lands for a consideration of \$1,800.00 plus H.S.T.
4. Easements - This Council does hereby authorize the transfer of such easements over the lands described in Schedule "A" attached hereto as required by utility providers, prior to conveyance to the abutting owner. Notice of the proposed road closings were sent to Hydro One Networks Inc., Bell Canada and Public Works Canada. All have responded that they do not have any easement requirements.
5. Sale of Land By-law - Compliance with the Notice provisions of By-law 2016-07, will be deemed to be compliance with the Notice provisions of this Municipality's Sale of Land By-Law 2013-13.
6. Clerk's Affidavit - There shall be attached to this By-law, as Schedule "B", an affidavit by the Clerk of this Corporation, setting out:
  - a) the procedures taken for the giving of Notice pursuant to By-law 2016-07; and,
  - b) the procedures taken for notice to Public Utilities and applicable Government Departments or Ministries.
7. Clerk's Compliance - There shall be included in the Clerk's Affidavit a statement affirming that the procedures taken by the Township are in compliance with By-law 2013-13.

READ A FIRST, SECOND, THIRD TIME AND FINALLY PASSED THIS 27th DAY OF FEBRUARY, 2024.

**THE CORPORATION OF THE  
TOWNSHIP OF BONFIELD**

---

Narry Paquette, Mayor

c/s

---

Nicole Kunkel, CAO/Clerk

BY-LAW 2024-13  
SCHEDULE "A"

SCHEDULE "A"

Part of the Original Shore Road Allowance in Front of Lot 2, Concession 7 being Part 1,  
36R15069, Township of Bonfield, District of Nipissing

---

BY-LAW CERTIFICATION

CERTIFIED to be a true copy of By-law 2024-13, and that such By-law is in full force and effect.

Dated at the Township of Bonfield, this the 27th day of February, 2024.

\_\_\_\_\_  
Nicole Kunkel, CAO/Clerk c/s



BY-LAW 2024-13  
SCHEDULE "B"

THIS IS SCHEDULE "B" TO BY-LAW 2024-13 FOR THE CORPORATION OF THE TOWNSHIP OF BONFIELD.

CLERK'S AFFIDAVIT

I, Nicole Kunkel, Chief Administrative Officer and Clerk of the Township of Bonfield, make oath and say as follows:

1. This Deponent  
I am the Chief Administrative Officer and Clerk of the Corporation of the Township of Bonfield and as such have knowledge of the facts hereinafter deposed to.
2. Publication and Posting  
Pursuant to By-law 2016-07, I did cause notice of the proposed by-law by the Corporation to stop up, close and sell that parcel of land described in Schedule "A" of By-law 2024-13:
  - (a) Publication - To be published in Community Voices (North Bay Nugget), a newspaper of local circulation, notice that the Township proposed to pass the subject By-law;
  - (b) Posting - Did post notice of the proposed By-law on site for at least two weeks before the meeting in two of the public places in the immediate neighbourhood of the proposed closure;
  - (c) Posting – did post notice of the proposed By-law in the Municipal Office;
  - (d) Website - Did post notice of the said By-law on the Township Website for at least the two week period preceding the meeting in which the By-law was presented;
  - (e) Notice contained the information required by By-law 2016-07.
3. Copy of Notice  
Attached to this my Affidavit as Exhibit "A" is a copy of the actual Public Notice as it appeared in Community Voices (North Bay Nugget) and as posted.
4. Additional Notification  
Notice of the proposed road closing was sent to Hydro One Networks Inc., Bell Canada and Public Works Canada. They responded that they do not have easement interest in the subject areas.
5. Procedure  
To the best of my knowledge the closing and selling procedures taken by this Township have been in accordance with Procedure By-law 2013-13.
6. Public Attendance  
The proposed by-law came before Council at its regular meeting on the 27th day of February, 2024 and at that time, no person made any claim that the effect of the By-law would be to deprive them of the right of motor vehicle access to or from their land, and that all persons who applied to be heard, were heard.

SWORN before me at the                    )  
Township of Bonfield                    )  
this the                    day                    )  
of \_\_\_\_\_, 2024.                    )

\_\_\_\_\_  
Nicole Kunkel, CAO/Clerk

A Commissioner for taking Affidavits, etc.  
Title: \_\_\_\_\_

BY-LAW 2024-13  
EXHIBIT "A"

This is Exhibit "A" to the Affidavit of Nicole Kunkel, Chief Administrative Officer and Clerk of The Corporation of the Township of Bonfield.

**Community Voices (North Bay Nugget)**

**THE CORPORATION OF THE TOWNSHIP OF BONFIELD**

**PUBLIC NOTICE**

**Re:** Closing of Part of the Original Shore Road Allowance in front of Lot 2, Concession 7 being Part 1, 36R15069, Township of Bonfield, District of Nipissing.

(Fleckney)

**TAKE NOTICE** that pursuant to Sections 34 and 270 of the *Municipal Act, 2001* and policies adopted by Council thereunder, the Council of the Corporation of the Township of Bonfield proposes to enact a by-law to stop up, close and sell part of the following road allowances:

Part of the Original Shore Road Allowance in front of Lot 2, Concession 7 being Part 1, 36R15069, Township of Bonfield, District of Nipissing.

**AND TAKE FURTHER NOTICE THAT** the proposed by-law will come before Council of the Township of Bonfield at its regular meeting at the Township office at 365 Highway 531, Bonfield on the 27th day of February 2024 at the hour of 7:00 in the evening.

**AND FURTHER TAKE NOTICE** that Council will consider comments from anyone in person, or by his/her counsel, solicitor or agent, at the foregoing meeting or, who in advance of the meeting, submits written comments to the Planning Administrator at the address listed below.

**PLAN 36R15069** is available for inspection at the Township offices.

**DATED** at the Township of Bonfield, this the 08th day of February, 2024.

Ann Carr, Planning Administrator  
Township of Bonfield  
365 Highway 531  
Bonfield, Ontario  
P0H 1E0

*This is Exhibit 'A' mentioned and referred to in the Affidavit of Nicole Kunkel.*

*SWORN before me this \_\_\_\_\_ day of \_\_\_\_\_, 2024.*

\_\_\_\_\_  
*A Commissioner for Taking Affidavits, etc.*

*Title: \_\_\_\_\_*



# Corporation of the Municipality of Calvin

## Council Resolution

**Date:** January 30, 2024

**Resolution Number:** 2024-31

**Moved By:** Councillor Moreton

**Seconded By:** Councillor Manson

**Background:** Before Calvin township became a township, it was burned by numerous forest fires. This was before the time of fire towers, water bombers, and municipal fire departments. A 1881 report from Lawrence Tallan, Provincial Land surveyor, states: *"The township of Calvin has been traversed by repeated and severe fires – so well have the flames done their work that with the exception of an insignificant portion, scarcely a vestige of the original timber remains."*

History has a way of repeating itself, and now rural municipalities and remote areas need more than ever to be prepared to respond to forest fires. Invasive pests like the emerald ash borer and the spruce bud worm are killing large numbers of trees, leaving copious amounts of dry kindling in our forests just waiting for a careless human or a lightning strike. Our forests are choked with deadfall and forest fires are becoming increasingly difficult to control. Add to this the effects of rising temperatures and drier seasons, or climate change, and we could be facing increasingly disastrous forest fires. This is not the time to be caught short with limited forest fire-fighting resources.

Jordan Omstead of the Canadian Press recently wrote: "But as Canada's water bombers age – and wildfire seasons are expected to intensify – some wildland

firefighters and emergency preparedness experts say the country needs to prop up its fleet of firefighting aircraft, even though several provinces are playing down concerns about capacity.” He quotes Eric Davidson, president of the Ontario Professional Association of Wildland Firefighters, “We’re really starting to see the effect of the aging fleet.”

The article further states the John Gradek, lecturer at McGill University estimates that almost half of the larger water bombers used to fight Canadian forest fires are nearing the end of their service life.

However, a Canadian company making a large skimmer-style water bomber is backed up with orders from European countries until the end of the decade.

Ontario has its own fleet of aircraft. They have 20 fixed-wing aircraft which includes 9 CL215 and CL415 water bombers that are 24 years old on average. The remaining 11 aircraft are an average of 54 years old. Melissa Candelaria, a spokesperson for Minister Graydon Smith says the MNR can handle Ontario fires with these aircraft, but Jennifer Kamau, communications manager for the Canada Interagency Forest Fire Centre, CIFFC, noted that other provinces contract out firebombers and last year there was a strain in Canada to get the resources to areas in need because there were so many fires across the country at the same time and very few aircraft available.

Peter Zimonjic of the CBC quoted the Canadian Association of Fire Chiefs (CAFC) President Ken McMullen, “It's not often that the fire chiefs sound the alarm. We are very concerned about this impending crisis that the summer of 2024 and beyond is going to bring our sector.”

In 2023 we all smelled the smoke and saw the sky turn brown. Buildings can be replaced, but lives cannot. And once an area is burned it takes more than a lifetime for it to return to its original state.

**WHEREAS** Forest fires are a very real threat to rural municipalities.



**AND WHEREAS** smoke from forest fires put people's health at risk. This is especially true of children and the elderly. The David Suzuki Foundation reports that wildfires kill many thousands of people per year and most of the deaths are from smoke inhalation.

**AND WHEREAS** forest fires are a very real danger to the climate and according to The Guardian, in 2023 they emitted three times as much carbon as the entire carbon footprint of Canada.

**AND WHEREAS** according to the John Crace interview in The Guardian with William Kurz, a retired scientist with Natural Resources Canada, around two billion tonnes of carbon have been released into the atmosphere from forest fires in 2023.

**AND WHEREAS** carbon emissions from forest fires are not counted against Canada's Paris agreement commitments, according to Kurz, but they far exceeded all of the emissions tied to Canada's economy (670 mega tonnes, or 0.67 billion tonnes, according to Environment and Climate Change Canada).

**AND WHEREAS** that standing healthy forest serves as a carbon sink, drawing in carbon, but once destroyed by fire, even though second growth takes its place, it is much less effective for many decades.

**AND WHEREAS** the federal government owns no water bombers and assists the provinces through the CIFFC, Canadian Interagency Forest Fire Centre, a spokesperson with CIFFC says that last year there were too many requests and not enough inventory to meet the needs of the country.

**AND WHEREAS** as reported by De Havilland Canada who manufacture the Canadian made water bomber, they have contracts with European countries for the next 22 of its new DHC-515 planes, which will take until 2029 or 2030 to complete and there will be very little production available to replace the aging water bombers in Ontario and the rest of Canada.

**NOW THEREFORE BE IT RESOLVED THAT** the council of the Corporation of Calvin Township urges and encourages the Federal Government to commit additional funds for cost sharing of provincial firefighting and to consider the development of a national strategy of firefighting. Furthermore, we urge the federal government to consider the measures necessary for acquiring a national fleet of Canadian-made waterbombers, with home bases strategically located to best serve and respond to the needs of rural communities, and a national fire administration to better coordinate and manage efforts across the country. We also encourage the introduction of a program similar to the Joint Emergency Preparedness Program (JEPP) which was ended in 2013.

And we encourage Minister Graydon Smith to step up the on-the-ground firefighting capability and water bomber acquisitions in Ontario.

**AND THAT** this resolution be forwarded to The Right Honourable Justin Trudeau, Prime Minister of Canada, The Honourable Bill Blair, Minister of National Defence, The Honourable Doug Ford, Premier of Ontario, The Honourable Graydon Smith, Minister of Natural Resources and Forestry of Ontario, The Honourable Vic Fideli, Minister of Economic Development Ontario, the Federation of Canadian Municipalities (FMC) and the Association of Municipalities Ontario (AMO).

**AND THAT** this resolution be shared with all 444 municipalities in Ontario for their consideration and adoption.

**Results: Carried**

**Recorded Vote:**

<u>Member of Council</u>	<u>In Favour</u>	<u>Opposed</u>
Mayor Gould	<input type="checkbox"/>	<input type="checkbox"/>
Councillor Moreton	<input type="checkbox"/>	<input type="checkbox"/>
Councillor Latimer	<input type="checkbox"/>	<input type="checkbox"/>
Councillor Grant	<input type="checkbox"/>	<input type="checkbox"/>
Councillor Manson	<input type="checkbox"/>	<input type="checkbox"/>



February 2, 2024

Larry Brock, MP Brant  
108 St. George Street, Suite #3  
Brantford, ON N3R 1V6

Sent via email: [larry.brock@parl.gc.ca](mailto:larry.brock@parl.gc.ca)

Will Bouma, MPP  
96 Nelson Street  
Suite 101  
Brantford, ON N3T 2X1

Sent via email: [will.bouma@pc.ola.org](mailto:will.bouma@pc.ola.org)

To whom it may concern:

Please be advised that Brantford City Council at its meeting held January 30, 2024 adopted the following:

**12.1.10 Reliable and Accessible Public Rail Transit - CN Rail**

WHEREAS Canadians deserve access to reliable and efficient passenger rail service; and

WHEREAS in 2021 the Canadian Minister of Transportation announced that the federal government would be pursuing opportunities to enhance passenger rail services in southwestern Ontario; and

WHEREAS passengers continue to experience long delays and disruptions to service, related to interruptions caused by CN Rail's freight systems and refusal to give priority to passenger rail service; and

WHEREAS Metrolinx and VIA, in extending or improving commuter train service from Aldershot through to Brantford, Woodstock, Ingersoll and London, is reliant on access to CN rail lines; and

WHEREAS CN Rail views increased passenger rail service on its lines as being incompatible with its primary business of moving freight and is unlikely to cooperate in extending commuter rail service on its lines in southwestern Ontario without direction from the federal government; and

WHEREAS CN Rail has shown a disregard for Municipal property maintenance standards in respect to the maintenance of their rail lines and blocks municipalities attempts to enforce municipal property standards upon their rail lines; and

WHEREAS CN Rail's consistent failure to provide a timely response to development applications adjacent to rail right of ways imposes inordinate delays and expense for builders and municipalities, further jeopardizing the ability of municipalities to address the housing crisis; and

WHEREAS there is a complete lack of federal regulations providing VIA and Metrolinx with any degree of priority or guaranteed access to rail rights of way or directing CN Rail to work cooperatively with municipalities;

AND WHEREAS The City of Brantford CALLS UPON the Federal Government to assist other levels of government as they take steps address the need for reliable and accessible public rail transit, timely processing of housing developments and the prompt and equitable enforcement of municipal property standards;

NOW THEREFORE THE COUNCIL OF THE CITY OF BRANTFORD requests that the Federal Government enact the necessary legislative and regulatory provisions:

- i. providing VIA and Metrolinx with priority right of way over freight rail lines, and further;
- ii. directing CN Rail to work positively and cooperatively with municipal and provincial governments in the processing of land development applications, and the prompt and timely enforcement of municipal property standards;

AND THAT a copy of this resolution be forwarded to all Ontario Municipalities; and to the Member of Provincial Parliament Will Bouma, Member of Parliament Larry Brock, Federal Minister of Transport Pablo Rodriguez, Provincial Minister of Transportation Prabmeet Singh Sarkaria, President and CEO at Metrolinx, President and Chief Executive Officer of VIA Rail Canada Inc and President and Chief Executive Officer of CN.

I trust this information is of assistance.

Yours truly,



Chris Gauthier  
City Clerk, [cgauthier@brantford.ca](mailto:cgauthier@brantford.ca)

cc Ontario Municipalities  
Federal Minister of Transport, Pablo Rodriguez  
Provincial Minister of Transportation, Prabmeet Singh Sarkaria  
President & CEO, Metrolinx



President & CEO, VIA Rail Canada Inc  
President & CEO, CN



February 7, 2024

**RE: Reaching Home Funding Allocations**

Hello Mayors and Councils of Nipissing District,

I am writing to the mayors and council of the 11 municipalities that form part of the District of Nipissing, to seek your support. The District of Nipissing Social Services Administration Board (DNSSAB) has seen reduced federal funding for the Reaching Home program for 2026-27 and 2027-28 in the amount of \$738,144 for each year. The Reaching Home program provides federal funding to urban, Indigenous, rural, and remote communities to help them address their local homelessness needs. This abrupt change will present significant financial challenges for the funded agencies providing homelessness services and supports with Reaching Home funds. Communities across Canada are advocating with the Federal Government to reconsider the funding cuts, and we are asking you to do the same. (See attached Board Report #HS-2024-003 for details on the funding cuts.)

The DNSSAB has also written letters to MPs Rota and Serré, also attached, asking them to advocate for reconsideration of the Reaching Home funding decreases.

We have provided a draft recommendation below should you wish to join this advocacy in support of our district's most vulnerable individuals. We ask that you bring this recommendation or one of your own design to your council and, if passed, to share that resolution with our local federal representatives.

**DRAFT RECOMMENDATION**

***THAT*** (your municipality) supports the stabilization of the Federal Government's Reaching Home funding to the District of Nipissing Social Services Administration Board as the Community Entity; and,

***THAT*** funding be maintained, at minimum, at current levels for future fiscal years; and,

***THAT*** this resolution be shared with local federal representatives.

Thank you sincerely for your continued support,

District of Nipissing  
Social Services  
Administration Board



Conseil d'administration  
des services sociaux  
du district de Nipissing

Kindest regards,

Mark King

Chair, District of Nipissing Social Services Administration Board

Cc: Melanie Shaye, Acting CAO, DNSSAB

Enc/ Board Report #HS-2024-003

## BOARD REPORT #HS-2024-003

**FOR INFORMATION**
*or*
 **FOR APPROVAL**

**Date:** January 31, 2024

**Purpose:** Reaching Home Funding Allocations

**Department Head:** Stacey Cyopeck, Director of Housing Services

**Approver:** Melanie Shaye, Acting Chief Administrative Officer

### RECOMMENDATION

**THAT** the District of Nipissing Social Services Administration Board (DNSSAB) approve Report HS-2024-003 outlining the recommended allocation of Reaching Home Winter Unsheltered Incremental funding for the 2023-24 Fiscal year; and,

**THAT** the DNSSAB receive and approve the recommended investment of the Reaching Home funding allocation for 2024-2028; and,

**THAT** the District of Nipissing Social Services Administration Board (DNSSAB) advocate to the Federal Government for stabilization of Reaching Home funding, including that the funding in future fiscal years, at minimum, be maintained at current levels, as outlined in the report.

### RELATIONSHIP TO STRATEGIC PLAN

#### Alignment with Strategic Plan 2022-2042: Healthy, Sustainable Communities

<input checked="" type="checkbox"/> <b>Maximize Impact</b>	<input checked="" type="checkbox"/> <b>Remove Barriers</b>	<input checked="" type="checkbox"/> <b>Seamless Access</b>	<input type="checkbox"/> <b>Learn &amp; Grow</b>
--	--	--	--

### BACKGROUND

Reaching Home Funding began in 2019, replacing the Homelessness Partnering Strategy. North Bay/Nipissing is one of 64 Designated Communities across Canada. The funding has Directives that are tied directly to the implementation of Coordinated Access and the compilation of data using the Homeless Individuals and Families Information System (HIFIS).

The DNSSAB, as Community Entity (CE), signed an original agreement with Canada for a total of \$1,190,764 base funding over five years:

Funding	2019/20	2020/21	2021/22	2022/23	2023/24	TOTAL
<b>Base RH Allocation</b>	\$229,153	\$219,153	\$250,486	\$245,986	\$245,986	\$1,190,764

Figure 1: Original Reaching Home 2019-2024 Funding

Reaching Home funding in Nipissing has been used to fund shelter supports, overflow, and, over the last two years, Warming Centre operations during the winter months. The funding has also been instrumental in the development and implementation of several local pilot projects, including the Housing Unit Stability and Recovery pilot, Suswin Outreach supports, and the Salvation Army's Emergency Rehousing Program.

Reaching Home Community and Capacity Innovation funding has been essential in the development and implementation of Coordinated Access Nipissing.

## FINANCIAL AND RISK CONSIDERATIONS

During the pandemic, incremental funding was added to the base amount and this funding had less stringent parameters for eligible expenses. In Nipissing, the incremental funding was primarily used to enhance and supplement funding for agencies continuing to offer services to households experiencing homelessness during the pandemic.

Funding Years	2019/20	2020/21	2021/22	2022/23	2023/24	TOTAL
<b>Incremental</b>	\$0	\$0	\$603,702	\$548,263	\$540,808	\$1,692,773
<b>Base RH Allocation</b>	\$229,153	\$219,153	\$250,486	\$245,986	\$245,986	\$1,190,764
<b>TOTAL RH Allocation with Incremental</b>	<b>\$229,153</b>	<b>\$219,153</b>	<b>\$854,188</b>	<b>\$794,249</b>	<b>\$786,794</b>	<b>\$2,883,537</b>

Figure 2: Reaching Home 2019-2024 with Incremental Funding

In 2022, the incremental funding was combined in an amended Agreement with the original base funding and, for 2022-23 and 2023-24, Nipissing used the enhanced base funding to fund new core services within the community, including the Warming Centre with the Gathering Place (TGP) and housing supports with the Brain Injury Association of North Bay and Area (BIANBA).

In late November of 2023, Infrastructure Canada (INFC) advised DNSSAB of the funding allocations for 2024-2028:

Funding	2024-25	2025-26	2026-27	2027-28	TOTAL
<b>Incremental</b>	\$492,158	\$492,158	\$0	\$0	\$984,316
<b>Base RH Allocation</b>	\$245,986	\$245,986	\$245,986	\$245,986	\$983,944
<b>TOTAL</b>	<b>\$738,144</b>	<b>\$738,144</b>	<b>\$245,986</b>	<b>\$245,986</b>	<b>\$1,968,260</b>

Figure 3: Reaching Home Funding 2024-28

In 2024-25 and 2025-26, overall funding for the fiscal year decreases by \$48,650 from the 2023-24 total funding. Funding for 2026-27 and 2027-28 will fall back to pre-pandemic levels. This decrease will add significant funding pressure within the system and could result in the loss of services and capacity.

On December 22, 2023, the DNSSAB received notification from INFC that winter incremental funding of \$222,599 was designated to Nipissing for priorities specific to homelessness pressures associated with unsheltered populations over the winter months. The funding may be used for eligible expenses from November 1, 2023, and must be fully expensed by April 30, 2024. Due to the short timelines for the winter incremental funding, Community Advisory Board (CAB) concurrence was not required for allocation decisions and INFC recommended that the funding be used to top up existing projects rather than create new projects. The incremental funding brings the total allocation for 2023-24 to \$1,009,393.

## RECOMMENDATIONS

**THAT** the DNSSAB support the following recommendations from the Community Advisory Board (CAB) at the meeting held January 10, 2024:

### Incremental Winter Funding 2023-24:

#### CAB Motion #2024-04:

- Fund temporary beds from November 2023 to April 2024 for individuals relocated as the result of an encampment intervention.
- Extend the Peer Outreach Support Team staffing and security weekday and weekend hours with True Self to April 30, 2024
- Enhance the staffing for the Warming Centre and allocate extra costs for security. With these enhancements, the expected total costs will be \$389,460.

Reaching Home Activity Area	Description	Anticipated Funding Allocation (\$)	Service Provider
Temporary Accommodations ( <i>new</i> ) (e.g., Leasing hotel/motel spaces to temporarily expand shelter space through the winter)	3 Units of temporary housing from November 2023 to April 2024 for individuals from encampment	\$40,020.00	Low Income People Involvement
Client Support Services (e.g. Hiring outreach workers to support those experiencing unsheltered homelessness, purchasing cold-weather supplies, expanding service availability)	Street Outreach and Security (extension of POST project to April 30 <sup>th</sup> , 2024)	\$69,067.96	True Self
	Extended Staffing and operational funding for Winter Warming Centre	\$24,835.00	The Gathering Place
	Security and other costs	\$55,286.19	DNSSAB
Administration costs associated with the delivery of the above expenditures ( <i>up to a maximum 15% of the contribution for the CE</i> )	Administrative tasks for C.E. – reporting, financial accountability to INFC	\$33,389.85	DNSSAB
<b>TOTAL</b>		<b>\$222,599.00</b>	

Figure 3: Winter Incremental Funding Allocation Recommendations

## 2024-25 Base Funding

**2024-25 Allocations to Sub-Projects:**

**CAB Motion #2024-05:**

- At the January 2024 CAB meeting, the CAB passed Motion #2024-05 recommending that all Sub-Project Agreements currently funded through the 2023-24 base Reaching Home Funding have their Funding Agreements amended to extend current funding to March 31, 2025. The funding shortfall will be taken from the Coordinated Access project funding, which will leave a balance of \$17,857.15 to be used for Coordinated Access and a Point in Time (PiT) count that is mandatory in the Fall of 2024.

Funded Sub-Projects	Budget
CCNB Shelter Supports Rehousing	\$162,407
CCNB Supporting Youth in Transitional Housing	\$73,716
BIANBA Housing Support Program	\$110,449
CCNB Youth Housing Support Program	\$110,993
TGP Cold Weather Unsheltered Hub	\$152,000
<b>TOTAL</b>	<b>\$609,565</b>

Figure 4: 2024-25 Project Funding Allocation Recommendations

- The extension for 2024-25 will allow for service and staffing stability.
- During the 2024-25 fiscal year, a thorough service evaluation and review of all currently funded sub-projects will be conducted jointly with the CAB to plan for 2025-26.

**2024-28 Funding Decreases**

- The abrupt changes announced for the Reaching Home Funding for 2026-27 and 2027-28 will present significant financial challenges for the DNSSAB and the agencies providing homelessness services and supports that are funded with Reaching Home funds. Communities across Canada are advocating with the Federal Government to reconsider the funding cuts.

**NEXT STEPS**

- Upon approval, current agreements with Sub-Project Agencies will be amended to reflect the funding allocations for 2023-24 and 2024-25.
- Recommend that DNSSAB communicate via letter with the Member of Parliament for Nipissing District, Anthony Rota, and Member of Parliament for Nickel Belt, Marc Serré, to advocate for reconsideration of the Reaching Home funding decreases.
- Recommend that DNSSAB collaborate with other leadership organizations, including AMO, NOSDA, OMSSA and CAEH within existing advocacy campaigns.

**AUTHOR:** Stacey Cyopec, Director of Housing Services

February 7, 2024

Anthony Rota  
Member of Parliament for Nipissing Timiskaming  
375 Main Street West  
North Bay, Ontario  
P1B 2T9  
[anthony.rota@parl.gc.ca](mailto:anthony.rota@parl.gc.ca)

**Re: Reductions in Reaching Home Funding**

Dear MP Rota:

The District of Nipissing Social Services Administration Board (DNSSAB) has been the Community Entity for the North Bay/Nipissing Community Advisory Board since signing the original Reaching Home Funding agreement with Canada in 2019. Since that time, this community has been in receipt of a total of \$3,106,136 over five years (2019-2024). This includes incremental funding of \$1,919,872 on top of base funding that was added during the pandemic (2021-2024). The additional funding has been essential to the provision of core community services including shelter supports and diversion, overflow beds and, over the last two years, Warming Centre operations during the winter months. The funding has also been instrumental in the development and implementation of several local pilot projects, including the Housing Unit Stability and Recovery pilot, Suswin Outreach supports, and the Salvation Army's Emergency Rehousing Program.

In late November of 2023, Infrastructure Canada (INFC) advised DNSSAB that the funding allocations for 2024-2028 would be decreasing by nearly \$1,000,000.00 to pre-pandemic levels with the loss of any incremental funding for 2026-2028. This decrease will add significant funding pressure within the system and could result in the loss of services and capacity.

It has become clear that the pandemic shone a bright light on the issue of homelessness – one that does not seem to have abated. The continued shortage of affordable housing, economic uncertainty and lack of access to mental health and addiction supports means that we are unlikely





to see a decline in need any time soon. Any loss of funding that, in turn, decreases services or capacity can only be expected to exacerbate the situation.

The DNSSAB respectfully requests that the District's MPs advocate for reconsideration of the cuts to Reaching Home Funding, and that the funding in future fiscal years, at minimum, be maintained at current levels.

Sincerely,

Mark King,

Chairperson

District of Nipissing Social Services Administration Board

Cc: Marc Serré, Member of Parliament for Nickel Belt

Melanie Shaye, A/CAO District of Nipissing Social Services Administration Board

Encl: Board Report HS2024-03 Reaching Home Funding Allocations

February 7, 2024

Marc Serré

Member of Parliament for Nickel Belt

206 King Street, Suite 3

Sturgeon Falls, Ontario

P2B 1R7

[marc.serre@parl.gc.ca](mailto:marc.serre@parl.gc.ca)

## **Re: Reductions in Reaching Home Funding**

Dear MP Serré:

The District of Nipissing Social Services Administration Board (DNSSAB) has been the Community Entity for the North Bay/Nipissing Community Advisory Board since signing the original Reaching Home Funding agreement with Canada in 2019. Since that time, this community has been in receipt of a total of \$3,106,136 over five years (2019-2024). This includes incremental funding of \$1,919,872 on top of base funding that was added during the pandemic (2021-2024). The additional funding has been essential to the provision of core community services including shelter supports and diversion, overflow beds and, over the last two years, Warming Centre operations during the winter months. The funding has also been instrumental in the development and implementation of several local pilot projects, including the Housing Unit Stability and Recovery pilot, Suswin Outreach supports, and the Salvation Army's Emergency Rehousing Program.

In late November of 2023, Infrastructure Canada (INFC) advised DNSSAB that the funding allocations for 2024-2028 would be decreasing by nearly \$1,000,000.00 to pre-pandemic levels with the loss of any incremental funding for 2026-2028. This decrease will add significant funding pressure within the system and could result in the loss of services and capacity.

It has become clear that the pandemic shone a bright light on the issue of homelessness – one that does not seem to have abated. The continued shortage of affordable housing, economic uncertainty and lack of access to mental health and addiction supports means that we are unlikely



to see a decline in need any time soon. Any loss of funding that, in turn, decreases services or capacity can only be expected to exacerbate the situation.

The DNSSAB respectfully requests that the District's MPs advocate for reconsideration of the cuts to Reaching Home Funding, and that the funding in future fiscal years, at minimum, be maintained at current levels.

Sincerely,

Mark King,

Chairperson

District of Nipissing Social Services Administration Board

Cc: Anthony Rota, Member of Parliament for Nipissing--Timiskaming

Melanie Shaye, A/CAO District of Nipissing Social Services Administration Board

Encl: Board Report HS2024-03 Reaching Home Funding Allocations

RECEIVED

FEB 20 2024

**BONFIELD & DISTRICT LIONS CLUB  
P.O. BOX 28  
350 LINE 3 SOUTH  
BONFIELD, ON P0H 1E0  
bonfieldlions@hotmail.ca  
http://e-clubhouse.org/sites/bonfield  
www.facebook.com/bonfieldLions**

February 20, 2024

Township of Bonfield  
365 Highway 531  
Bonfield, ON P0H 1E0

**Subject: 20<sup>th</sup> Annual Bonfield & District Lions Blue Sea ATV Fundraiser & Poker Run**

Dear Council of the Corporation of the Township of Bonfield,

The Bonfield & District Lions Club is holding its 20th ATV Fundraiser on May 11, 2024 starting at 8:30 a.m. from the Lions Den located at 350 Line 3 South in Bonfield. We would like to inform you that funds raised from this event will be used for Bonfield & District Lions Club, special Projects in Bonfield, and various local charities.

We have requested the assistance of the Bonfield Fire Department's First Response Team during this event to ensure that it is a safe and enjoyable day for all participants.

After the ATV Run we will be having a Pasta Dinner and an Awards Presentation and alcohol will be served with a Special Occasions Permit.

As we expect quite a few riders from out of the area, we would also like to request the use of the Township Garage site for overflow parking of participant vehicles during the day. There will be Lions directing the parking in this area as well as at the Lions Club.

We would like to ask the Council of the Corporation of the Township of Bonfield for permission to use any available picnic tables, Garbage Bins for our event.

**A reply acknowledging receipt of this letter for our Special Occasion Permit Application would be appreciated.**

Please feel free to contact me at 705-471-8291 or bonfieldlionsatv@gmail.com with any questions or concerns. Thank you.

Yours in Lionism,

Donald Lemieux

Lion Don Lemieux  
Chair, Blue Sea ATV Fundraiser & Poker Run 2024



February 2, 2024

Nicky Kunkel  
Township of Bonfield  
365 Hwy 531  
Bonfield ON P0H 1E0

Dear Nicky,

In January 2024, the District of Nipissing Social Services Administration Board passed the 2024 budget which includes an overall increase in the levy of \$674,772 year over year. Using the 2023 Property Assessment Rolls and the 2023 tax ratios of the Municipalities in our district, the levy is apportioned amongst the Municipalities using a weighted assessment.

Please find enclosed the worksheet showing the calculation of the apportionment of the municipal share of the 2024 Budget amongst the Municipalities in the District of Nipissing and Territories Without Municipal Organization (TWOMO). Also included is the calculation showing the adjusted invoice amount for March 2024, and the amount to be invoiced monthly for the balance of the year to December 31, 2024.

Should you have any questions regarding this calculation, please do not hesitate to contact me directly. I can be reached at (705) 474 - 2151 ext. 63350, or at [justin.avery@dnssab.ca](mailto:justin.avery@dnssab.ca)

Yours truly,

Justin Avery, CPA, CA  
Manager of Finance

District of Nipissing Social Services Administration Board  
 2024 Approved Budget \$- Municipal Apportionment

The weighted assessment figures have been calculated using 2023 Assessment Rolls and 2023 Tax Ratios.  
 There are no Tax Ratios available for the Unincorporated Townships.

Municipality	A - Current Value Assessment Method used to determined Unincorporated share only			B - Weighted Assessment Method (Excl. PIL) - Actual			2024 Monthly Levy =Col.6/12	2023 Budget Allocation	Variance Yr over Yr Budget Allocataion	Variance % Change
	Current Value Assessment-2023	%	Budget Allocation	Weighted Assessment-2023	%	Budget Allocation				
	1	2	3	4	5	6				
	7									
City of North Bay	5,750,171,275		-	6,816,694,640	60.6317%	14,087,246	1,173,937	13,713,389	373,857	2.73%
Municipality of West Nipissing	1,664,503,615		-	1,746,106,052	15.5309%	3,608,468	300,706	3,467,087	141,381	4.08%
Municipality of East Ferris	705,125,211		-	707,115,091	6.2895%	1,461,310	121,776	1,396,859	64,451	4.61%
Municipality of Temagami	500,599,300		-	504,769,248	4.4897%	1,043,146	86,929	1,018,349	24,797	2.44%
Township of Bonfield	302,200,710		-	289,816,486	2.5778%	598,929	49,911	577,956	20,973	3.63%
Township of South Algonquin	270,563,200		-	280,914,769	2.4986%	580,533	48,378	563,508	17,025	3.02%
Township of Papineau-Cameron	169,460,100		-	155,029,777	1.3789%	320,381	26,698	308,522	11,859	3.84%
Town of Mattawa	109,104,325		-	118,947,767	1.0580%	245,815	20,485	236,841	8,975	3.79%
Township of Chisholm	158,671,400		-	149,975,842	1.3340%	309,937	25,828	298,615	11,322	3.79%
Municipality of Calvin	92,274,900		-	128,356,972	1.1417%	265,260	22,105	258,371	6,889	2.67%
Township of Mattawan	28,457,100		-	28,342,698	0.2521%	58,572	4,881	56,733	1,840	3.24%
<b>Sub Total Municipalities</b>	<b>9,751,131,136</b>		<b>22,579,598</b>	<b>10,926,069,339</b>	<b>97.1829%</b>	<b>22,579,598</b>	<b>1,881,633</b>	<b>21,896,228</b>	<b>683,369</b>	<b>3.12%</b>
TWOMO - (MCCSS, EDU, & MMAH)	407,372,200		654,523							
	-		-							
<b>Sub Total Unincorporated</b>	<b>407,372,200</b>	<b>4.01%</b>	<b>654,523</b>	<b>407,372,200</b>	<b>2.8171%</b>	<b>654,523</b>	<b>54,544</b>	<b>663,121</b>	<b>-8,597</b>	<b>-1.30%</b>
<b>TOTAL</b>	<b>10,158,503,336</b>		<b>23,234,121</b>	<b>11,333,441,539</b>	<b>100.0000%</b>	<b>23,234,121</b>	<b>1,936,177</b>	<b>22,559,349</b>	<b>674,772</b>	<b>2.99%</b>
			Municipal share net of EMS			23,234,121				
			EMS Budget (municipal share)			654,523				
						22,579,598				

Note: TWOMO share of DNSSAB costs  
 excludes Emergency Medical Services Costs



## **FOR IMMEDIATE RELEASE**

14-Feb-2024

DNSSAB hires a new CAO

**NORTH BAY** - The District of Nipissing Social Services Administration Board officially welcomes Melanie Shaye as its next Chief Administrative Officer (CAO).

The Board approved the decision to hire Ms. Shaye during a special meeting held on 14-Feb-2024 following a thorough recruitment process that began upon the resignation of the former CAO Catherine Matheson on 31-Oct-2023.

Ms. Shaye holds an Honours Bachelor of Arts degree from Wilfrid Laurier University, a mini-MBA Business Certificate from the University of British Columbia, and a postgraduate HR Management Diploma from Sheridan College.

She has been a long-time member of DNSSAB's senior management team, having served as Director of Corporate Services since 2017 and as the acting CAO in 2019 and since Nov-2023. Ms. Shaye also held a management position with the County of Wellington where she worked for close to 14 years.

Ms. Shaye brings a strong understanding of the challenges unique to the District of Nipissing, particularly as DNSSAB confronts important issues around housing and homelessness,, income security and social assistance reform, early childhood educator recruitment and retention, and emergency medical support.

"I am excited to work with the DNSSAB's amazing staff and the senior leadership team to support the Board and their vision for sustainable communities in the district." CAO Melanie Shaye said.

"On behalf of the Board, I'm pleased to introduce and welcome Melanie to her new role. With her proven leadership, experience, and knowledge, especially of our District, this Board is confident that she will meet the needs of the citizens while bringing an invaluable focus to the organization as it continues to move forward," Chair Mark King said.

Ministry of Transportation

Ministère des Transports



Assistant Deputy Minister's Office  
Integrated Policy and Planning  
Division

Bureau du sous-ministre adjointe  
Division des politiques et de la  
planification intégrées

438 University Avenue  
12<sup>th</sup> Floor  
Toronto ON M5G 2K8  
Tel. (647) 302-7129

438 Avenue University  
12<sup>e</sup> étage  
Toronto ON M5G 2K8  
Tel. (647) 302-7129

**Memo to Chief Administrative Officers re:  
Licence Plate Renewal**

I am writing to provide further information regarding the Government of Ontario's announcement on Feb. 15, 2024, regarding proposed changes to the way licence plates are renewed in Ontario.

The government has announced it will be introducing legislation related to the renewal of licence plates in the coming days, and more details regarding the proposed changes will be released over the coming months.

It is important to note the Government of Ontario is not eliminating licence plate renewals nor is it proposing changes to the plate denial process. The introduction of a new plate renewal process will not change the way municipalities collect unpaid fines.

Plate denial information will continue to support municipal fine collection. As a plate nears its expiry date, the automated system will check if the plate has fines, outstanding tolls, or insurance issues. If the plate has none of these issues, it will be renewed automatically for one year. If the plate has any of these issues, renewal will not proceed and the vehicle owner will be notified that they need to take action, which will include paying any fines or their plate will expire.

Expired plates will continue to be subject to roadside enforcement.

MTO and partner ministries have consulted with key stakeholders, including municipal court managers, throughout the development of this proposal. Further consultations will be held in spring 2024 to discuss the proposal in more detail.

We thank you for your support on this important initiative.

If you have further questions, please contact Katie De Palma at [katie.depalma@ontario.ca](mailto:katie.depalma@ontario.ca).

Sincerely,

Jonathan Lebi, Assistant Deputy Minister  
Ministry of Transportation



February 23<sup>rd</sup>, 2024

Ms. Nicky Kunkel  
CAO/Clerk  
Township of Bonfield  
365 Hwy 531  
Bonfield, ON P0H 1E0

Dear Ms. Kunkel

Re: Cassellholme 2024 Municipal Operating Levy

On November 23<sup>rd</sup>, 2023, the Cassellholme Board of Management approved the 2024 Operating Budget. On February 22<sup>nd</sup>, 2024, the Board approved the 2024 apportionment statistics which will apply to the operating levy for Cassellholme East Nipissing District Home for the Aged.

This operating budget includes a 0% increase to the municipal levy over the amount levied for 2023. Note, that while the overall operating levy has not changed, your municipality's apportionment will fluctuate based on its apportionment statistics.

November 23<sup>rd</sup>, 2023 - *Resolution No. 110-23*

*"That the Board approve Cassellholme's 2024 Operating Budget, as presented. The Levy Apportionment will be approved at a later date once all the member municipalities have submitted their 2022 FIRs to the Ministry"*

*Moved by: Chris Mayne (Municipality of North Bay)*

*Seconded by: Robert Corriveau (Township of Papiniveau/Cameron)*

February 22, 2024 - *Resolution No. 22-24*

*"That the Board approve the 2024 apportionment statistics for calculating the Cassellholme municipal levy, as presented"*

*Moved by: Peter Chirico (City of North Bay)*

*Seconded by: Chris Mayne (City of North Bay)*

Attached is Schedule A - Levy Apportionment noting each municipality's portion.

Sincerely,

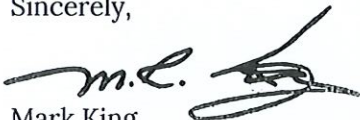

Mark King  
Cassellholme Board Chair

CC: Mayor Narry Paquette

**Schedule A - Operating Levy Apportionment**  
 Budget Period 2024



Compassionate care for life's journey.

Total Levy - 2024 3,343,403

Municipality	Apportionment Rate	2024 Calculated		12 Monthly Payments - Jan -		Total Levy Requested
		Operating Levy	December 15th, 2024	December 15th, 2024	Total Levy Requested	
North Bay	79.187%	2,647,538	220,628.16	2,647,537.92		2,647,537.92
East Ferris	7.742%	258,857	21,571.41	258,856.92		258,856.92
South Algonquin	3.316%	110,857	9,238.08	110,856.96		110,856.96
Bonfield	3.237%	108,228	9,019.00	108,228.00		108,228.00
Papineau-Cameron	1.726%	57,712	4,809.33	57,711.96		57,711.96
Chisholm	1.633%	54,612	4,551.00	54,612.00		54,612.00
Calvin	1.482%	49,560	4,130.00	49,560.00		49,560.00
Mattawa	1.347%	45,042	3,753.50	45,042.00		45,042.00
Mattawan	0.329%	10,997	916.41	10,996.92		10,996.92
<b>Total</b>	<b>100.000%</b>	<b>3,343,403</b>	<b>278,616.89</b>	<b>3,343,402.68</b>		<b>3,343,402.68</b>

Check - 3,343,402.68

**FIR Information Used** Tab 26A Column 17 Row 9199 & 9299

Municipality	2022		Phased-In PII		Total	Apportionment	Share of Operating Levy
	Phased-In Taxable Assessment (Wtd. & Disc CVA)	Phased-In PII Assessment (Wtd. & Disc CVA)	Phased-In PII Assessment (Wtd. & Disc CVA)	Phased-In PII Assessment (Wtd. & Disc CVA)			
North Bay	6,650,977,171	244,953,412	6,895,930,583	79.187%	2,647,538	2,647,538	79.187%
East Ferris	673,133,727	1,101,000	674,234,727	7.742%	258,857	258,857	7.742%
South Algonquin	278,589,277	10,154,594	288,743,871	3.316%	110,857	110,857	3.316%
Bonfield	280,778,502	1,119,093	281,897,595	3.237%	108,228	108,228	3.237%
Papineau-Cameron	149,223,463	1,095,475	150,318,938	1.726%	57,712	57,712	1.726%
Chisholm	142,199,146	45,204	142,244,350	1.633%	54,612	54,612	1.633%
Calvin	126,093,591	2,993,201	129,086,792	1.482%	49,560	49,560	1.482%
Mattawa	116,264,123	1,054,850	117,318,973	1.347%	45,042	45,042	1.347%
Mattawan	27,741,887	901,977	28,643,864	0.329%	10,997	10,997	0.329%
<b>Total</b>	<b>8,445,000,886</b>	<b>263,418,806</b>	<b>8,708,419,692</b>	<b>100.000%</b>	<b>3,343,403</b>	<b>3,343,402.68</b>	<b>100.000%</b>

## AC2024: REGISTRATION NOW OPEN

Lynn Hall <lhall@fcm.ca>

Wed 2/14/2024 9:49 AM

You don't often get email from lhall@fcm.ca. [Learn why this is important](#)

Good morning,  
In case you did not receive this, I am resending.

Thank you for your patience,  
Lynn

[EXTERNAL EMAIL]

[Click here to view this email in your browser.](#)



February 13, 2024



## AC2024: REGISTRATION NOW OPEN

This is the moment you've been waiting for! Registration for [FCM's 2024 Annual Conference and Trade Show](#) (AC2024) is now open.

From June 6-9, join over 1,000 elected officials and FCM partners in Calgary for *Redefining our future*, FCM's 2024 Annual Conference and Trade Show and the largest gathering of municipal leaders in Canada.

Through our thoughtfully chosen activities and programming, AC2024 will help you foster connections with your peers, partners and federal representatives. You will gain the tools and insights to address challenges and embrace new opportunities for municipal success. Throughout AC2024, delegates will explore how a new **Municipal Growth Framework** will empower municipalities with solutions.

**Book your trip**

For help booking a trouble-free trip to Calgary, please see the [Travel](#) and [Accommodation](#) pages on our website for special rates and recommendations to make your stay comfortable and convenient.

### Choose from a wide range of activities

Our comprehensive [programming](#) promises to keep you busy! Discover our wide range of conference activities, tailored to suit all interests including engaging workshops, presentations, plenaries, receptions, our trade show, and so much more. Make the most of your time in Calgary by immersing yourself in the rich experiences our host city has to offer through our engaging [study tours](#).

Get ready to be part of something extraordinary and stay tuned for exciting updates and announcements that will make your conference experience in Calgary truly unforgettable.

**It's time to register!** Early-bird rate applies until April 19.

[REGISTER NOW!](#)



24 Clarence Street  
Ottawa, Ontario K1N 5P3  
T. 613-241-5221  
[fcm.ca](http://fcm.ca)

[Privacy Policy](#)  
[Unsubscribe here](#).



© 2024 Federation of Canadian Municipalities

### Lynn Hall

Member Relations Advisor | Policy and Public Affairs  
Conseillère des Relations avec les membres | Politiques et affaires publiques  
T. 1-613-907-6273





As we move forward with our commitment to reconciliation, FCM acknowledges that our head offices are located on the unceded, unsundered territory of the Anishinaabe Algonquin Nation whose presence here reaches back to time immemorial. We recognize and honour the historic and ongoing contributions of Indigenous peoples across the country. [Full Statement](#)

Dans le cadre de son engagement pour favoriser la réconciliation, la FCM tient à reconnaître que ses sièges sociaux sont situés sur le territoire non cédé de la Nation anichinabée algonquine, présente en ces lieux depuis des temps immémoriaux. Nous reconnaissons également les contributions passées et présentes des peuples autochtones au pays. [Déclaration complète](#)

**THE CORPORATION OF THE TOWNSHIP OF BONFIELD**

**BY-LAW NO. 2024-09**

**BEING A BY-LAW TO CONFIRM THE PROCEEDINGS OF COUNCIL**

**WHEREAS** it is the desire of Council to confirm all Proceedings and By-Laws:

**NOW THEREFORE** the Council of the Corporation of the Township of Bonfield **ENACTS AS FOLLOWS:**

1. THAT the Confirmatory Period of this By-Law shall be for all Regular Council and Special Meetings from February 13, 2024 to February 27, 2024 inclusive.
2. THAT all By-Laws passed by the Council of the Township of Bonfield during the period mentioned in Section 1 are hereby ratified and confirmed.
3. THAT all resolutions passed by the Council of the Township of Bonfield during the period mentioned in Section 1 are hereby ratified and confirmed.
4. THAT all other proceedings, decisions and directions of the Council of the Township of Bonfield during the period mentioned in Section 1 are hereby ratified and confirmed.

**READ A FIRST, SECOND, AND THIRD TIME AND FINALLY PASSED THIS 27th DAY OF FEBRUARY 2024.**

---

MAYOR

---

CLERK